

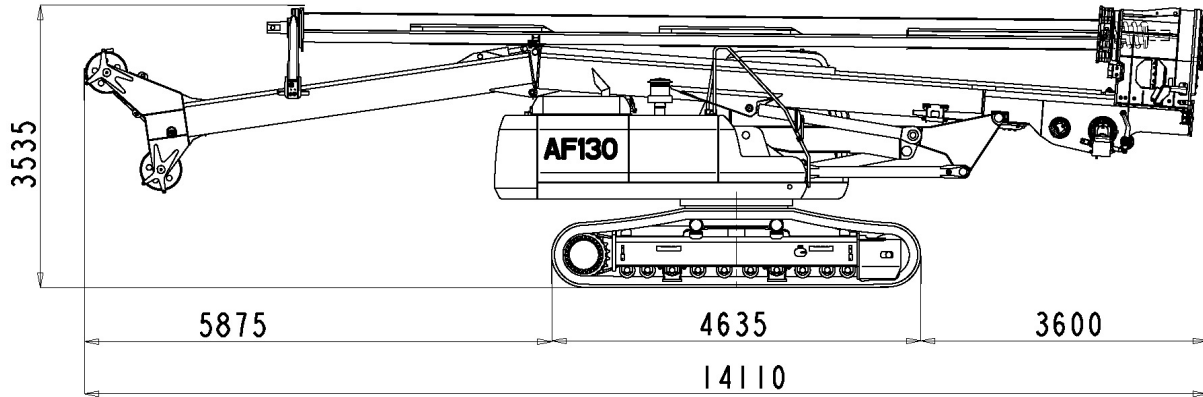

AF 130



Base	DAEWOO 255 LN
Undercarriage length/width/shoe	STD 4635/2990/600
Engine type	DAEWOO DB58TIS
Power - rpm	121 KW (162 HP) @ 2000 rpm
Rotary	
Installed torque (kNm)	117
Working speed (rpm)	7,8 - 27
Discharge speed (rpm)	50 - 120
Winches	
Main pull force (KN)	120
Main winch speed (m/min)	90
Cable diam. (mm)	22
Auxiliary winch (KN)	60
Speed (m/min)	90
Cable diam. (mm)	15
Crowd system	
Kelly crowd push (KN)	100
Kelly crowd pull (KN)	165
Stroke (mm)	3325
Mast	
Mast raking forward	5°
Mast side raking	± 5°
Mast raking backwards	15°
Pile max. diameter	1500
Kelly bar	
Standard	3/28 - 4/38
Options available	4/33 - 5/47
"Operating Weight w/standard kelly bar (t)"	33

Measurements in working phase

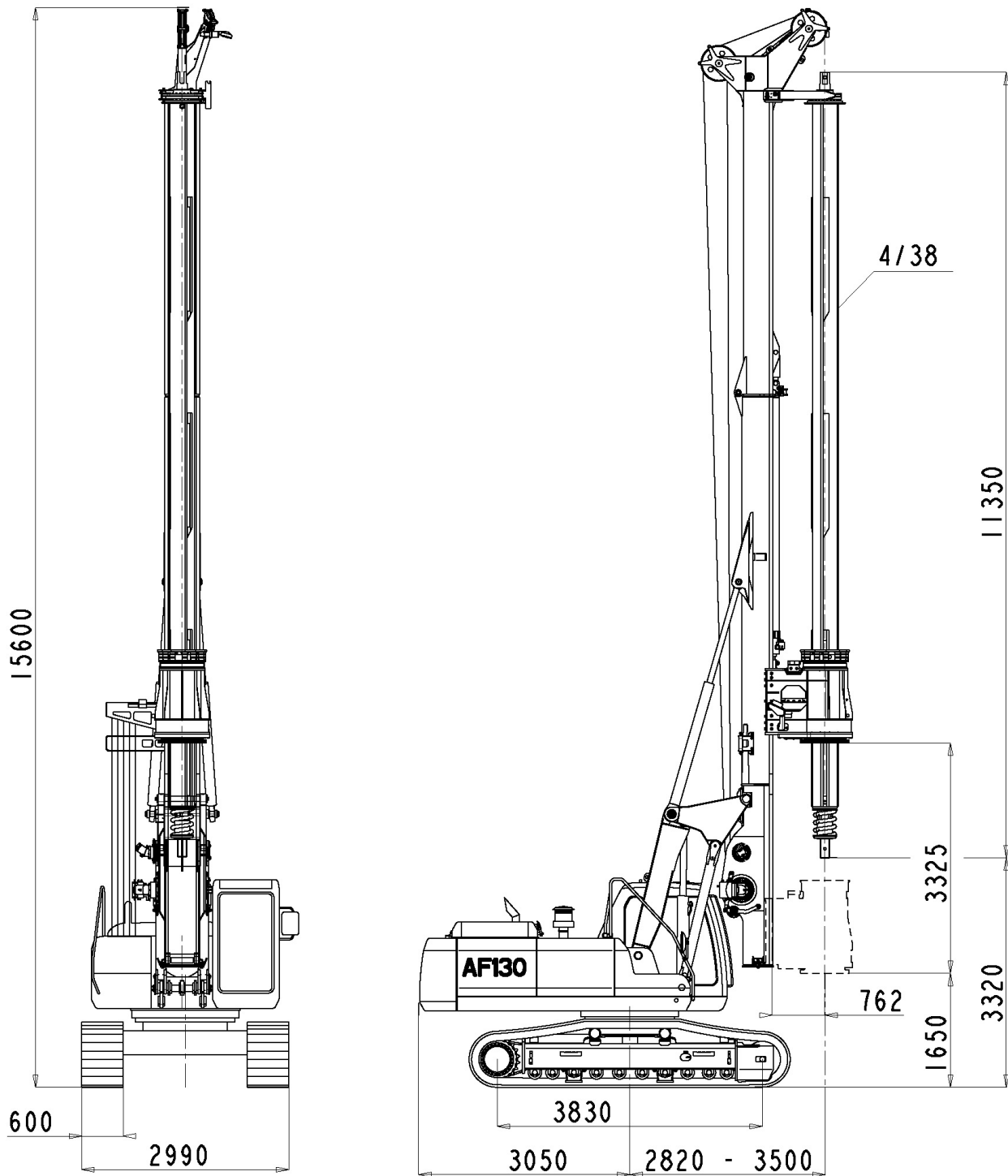

I.M.T. INTERNATIONAL S.p.A.

Legal Headquarters:

Via dei Gracchi, 91 - 00192 Roma Italy

Offices and Plant:

Via d'Ancona, 39 - 60027 Osimo (An) - Italy

Tel. + 39 071 723341 r.a.

Fax + 39 071 7133352

<http://www.imtspa.com>

e-mail: imt@imtspa.com

All technical data are purely indicative and subject to change without notice.