



casagrande



Hydraulic foundation rig
Attrezzatura idraulica per fondazioni

B250



Prestazioni Pali

Piling

Profondità max.	Max. depth	222 ft	67,8 m
Diametro max.	Max. diameter	98 in	2500 mm
Diametro max. con tubo - Martinetto pull-down	Max. diameter with casing - Crowd ram	79 in	2000 mm
Diametro max. con tubo - Argano pull-down	Max. diameter with casing - Crowd winch	71 in	1800 mm
Diametro max. con morsa giracolonna	Max. diameter with casing oscillator	59 in	1500 mm

Elica continua C.F.A.

C.F.A. continuous flight auger

Profondità max.	Max. depth	88.6 ft	27 m
Diametro max.	Max. diameter	4 ft	1200 mm

Diaframmi

Diaphragm wall

Profondità max.	Max. depth	116.8 ft	35,6 m
Lunghezza max. scavo	Max. length of trench	9.8 ft	3000 mm
Larghezza max. scavo	Max. width of trench	4 ft	1200 mm

Caratteristiche Carro

Undercarriage

Larghezza cingoli chiusi	Width with retracted tracks	9.8 ft	3000 mm
Larghezza cingoli aperti	Width with extended tracks	14.7 ft	4500 mm
Lunghezza cingoli	Tracks length	18.2 ft	5545 mm
Larghezza pattini	Shoes width	35.4 in	900 mm

Motore

Engine

DEUTZ AG TCD 2015 V06 (EPA/COM III)

Potenza a 2100 rpm	Power at 2100 rpm	443 HP	330 kW
--------------------	-------------------	--------	--------

Argano principale

Main winch

Tiro max.	Max. line pull	49,460 lbs	220 kN
Velocità max. fune	Max. line speed	294 ft/min	90 m/min

Argano ausiliario

Auxiliary winch

Tiro max.	Max. line pull	25,000 lbs	110 kN
Velocità max. fune	Max. line speed	197 ft/min	60 m/min

Testa rotary

Rotary head

H25

Coppia max.	Max. torque	160 ft lb	217 kNm
Velocità max. lavoro	Max. drilling speed	34 rpm	34 rpm
Velocità di scarico	Max. discharge speed	120 rpm	120 rpm

Martinetto pull-down

Crowd ram

Tiro max.	Max. line pull	47,435 lbs	211 kN
Spinta max.	Max. crowd	41,000 lbs	180 kN
Corsa	Stroke	19.7 ft	6000 mm

Argano pull-down

Crowd winch

Tiro max.	Max. line pull	54,000 lbs	240 kN
Spinta max.	Max. crowd	54,000 lbs	240 kN
Corsa	Stroke	41 ft	12500 mm

Peso

Weight

Attrezzatura in condizioni di lavoro	Weight in working condition	~176,400 lbs	~80 t
--------------------------------------	-----------------------------	--------------	-------



B250

Composizioni generali e dimensioni General arrangement and dimensions

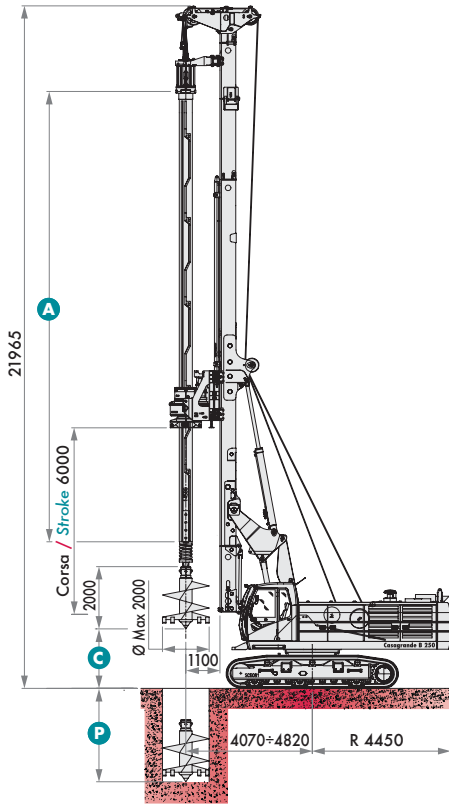

Martinetto pull - down
Crowd ram

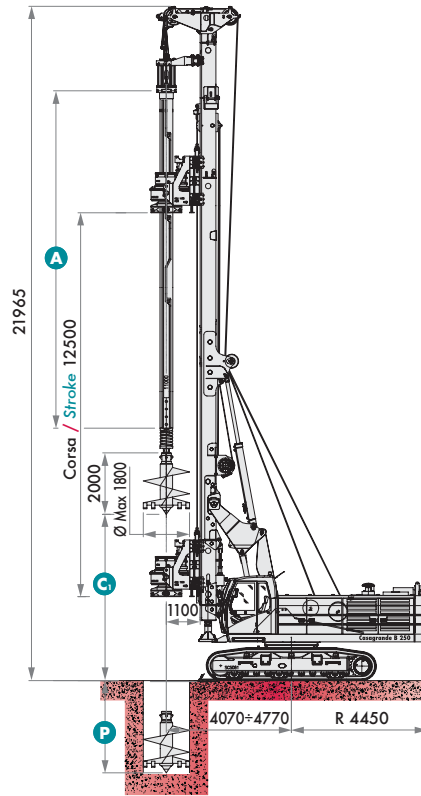

Argano pull - down
Crowd winch

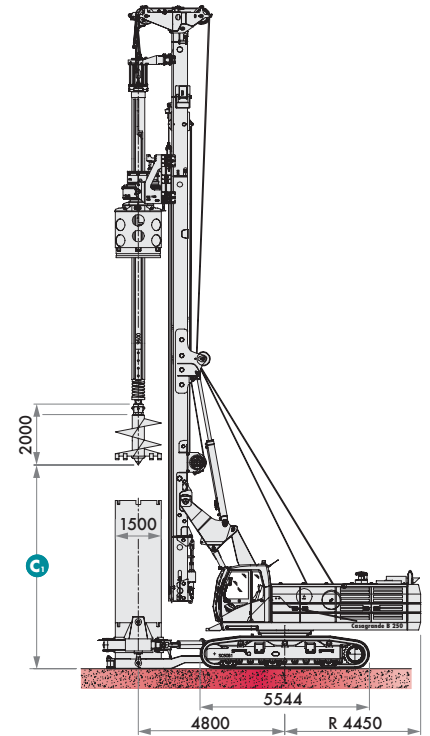

Applicazione Morsa Giracolonna
Casing Oscillator Application

Profondità di scavo • **Drilling depth**

A	Lunghezza nominale aste <i>Nominal kelly bars length</i>	7500	9500	11000	12500	14500
	Aste bloccaggio - 4 elementi <i>Interlocking type kelly bar - 4 elements</i>	mm 25900	33900	39900	45900	53900
		ft 85	111	131	151	177
P	Aste a frizione - 5 elementi* <i>Friction type kelly bar - 5 elements*</i>	mm 32850	42850	50350	57850	67850
		ft 108	141	165	190	223
	Aste a frizione - 4 elementi <i>Friction type kelly bar - 4 elements</i>	mm 26350	34350	40350	46350	54350
		ft 87	113	132	152	178
C	Altezza max. utensile da terra <i>Max. ground clearance</i>	mm 5750	5750	5420	3920	1920
		ft 19	19	18	13	6
C₁	Altezza max. utensile da terra <i>Max. ground clearance</i>	mm 8920	6920	5420	3920	1920
		ft 29	23	18	13	6

*Coppia rotary ridotta a 185 kNm / *Torque limited at 185 kNm*



B250

Allestimento elica continua C.F.A C.F.A. continuous flight auger

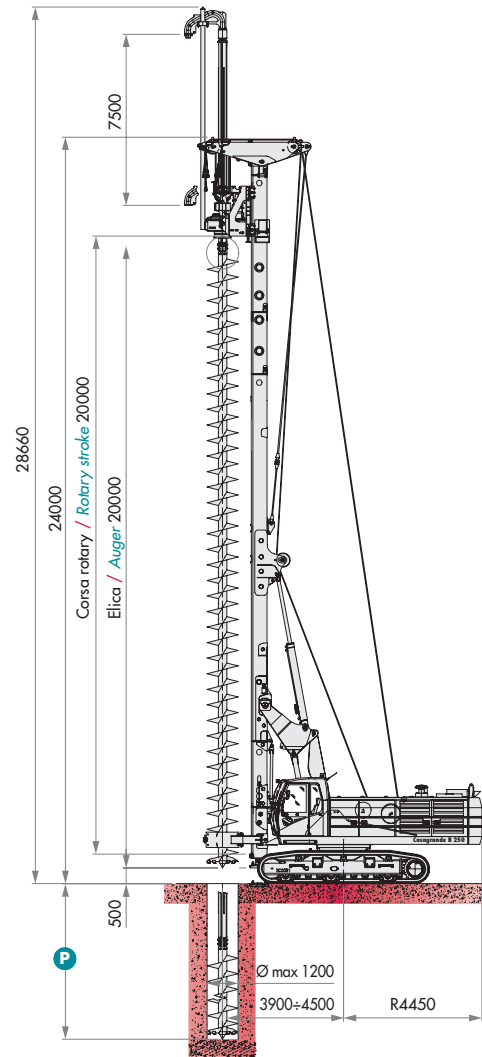

D	Diametro max. <i>Max. diameter</i>	mm	1200
		ft	4
P	Profondità max. con pulisci elica stellare <i>Max. depth with star auger cleaner</i>	mm	19500 + 7500
		ft	64 + 24,6
	Forza di estrazione <i>Extraction force</i>	kN	800
		lbf	180,000
	Argano pull down* <i>Crowd winch*</i>	kN	70
		lbf	15,740

*Optional / *Optional*

Fase di trasporto • *Transport mode*

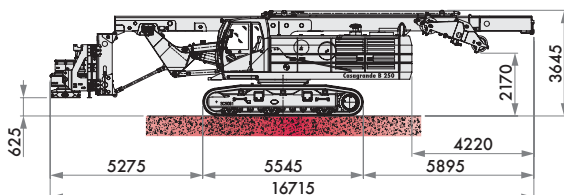

Versione pali
Piling arrangement

Peso ~ 66000 kg
Weight ~ 65 ton

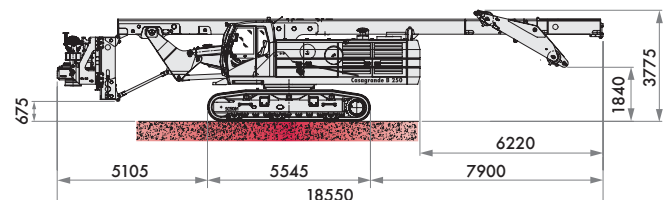

Versione CFA
CFA arrangement

Peso ~ 67000 kg
Weight ~ 66 ton

Allestimento diaframmi KRC2-180° KRC2-180° diaphragm wall

B250

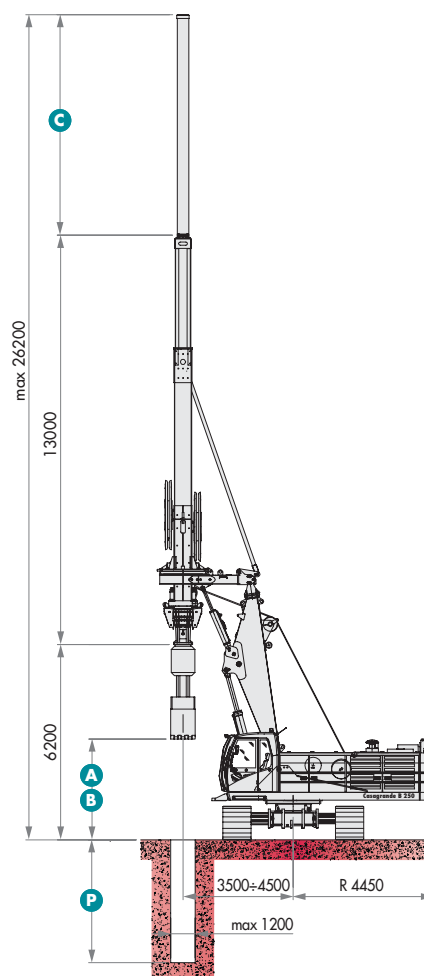

Benna idraulica • Hydraulic Grob

A Altezza da terra a valve chiuse / Height with closed jaws

K 2500HD

3000 / 9.8

K 3000HD

2330 / 7.6

Applicazione distanziale 1000 • Extension 1000

B Altezza da terra a valve chiuse / Height with closed jaws

2000 / 6.5

1330 / 4.4

C Prolunga / Extension	P m/ft	P m/ft
-	28,2/92.5	28,6/94
2000	30,2/99	30,6/100.4
5000	33,2/109	33,6/110
7000	35,2/115.5	35,6/117

Fase di trasporto • Transport mode

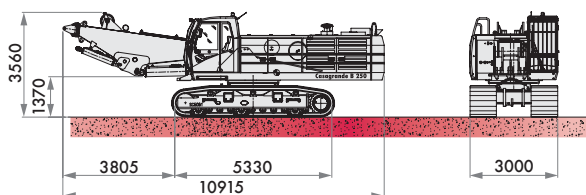

Versione Kelly
Kelly arrangement

Peso ~ 54000 kg
Weight ~ 53.2 ton

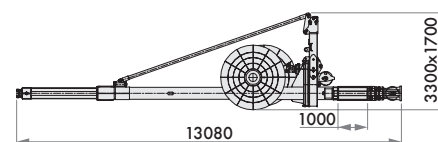

Peso ~ 15000 kg
Weight ~ 14.8 ton



OPTIONAL

Applicazione telecamera con monitor da 5,6' per controllo tamburo argano principale

Applicazione due telecamere con monitor da 5,6', per controllo tamburo argano principale e spazio dietro alla torretta

Sollevamento idraulico zavorra

Insonorizzazione

Impianto per l'ingrassaggio automatico

Kit per l'avviamento alle basse temperature

Impianto standard per morsa

Argano principale Zollern a discesa libera e controllata - tiro nominale 220 kN

Argano ausiliario Zollern a discesa libera e controllata - tiro nominale 120 kN

Dispositivo controllo verticalità/profondità tipo V2

Dispositivo controllo automatico verticalità tipo V3

Pulitore elica rotante

Pulisci elica stellare

Vibratore per gabbie

Apparecchiatura Lutz per la misurazione, la visualizzazione e la registrazione digitale dei seguenti parametri:

- profondità
- pressione del calcestruzzo
- portata e volume del calcestruzzo
- inclinazione del mast su due assi

L'apparecchiatura è completa di software per l'elaborazione dei dati su PC

Dispositivo per la trasmissione tramite telefono cellulare dei parametri di lavoro rilevati dall'apparecchiatura Lutz

Kit risalita automatica per CFA per apparecchiatura Lutz

Video unit with camera and 5.6' monitor to control the main winch drum

Video unit with two cameras and one 5.6' monitor to control the main winch drum and the space behind upperstructure

Hydraulic lifting cylinder for counterweight

Soundproofing

Kit for automatic greasing

Kit for starting engine at low temperature

Hydraulic circuit for oscillator

Main winch, free-controlled fall type Zollern ZHP- nominal line pull 220 kN

Auxiliary winch, free fall type Zollern ZHP- nominal line pull 120 kN

V2 verticality/depth control device

V3 automatic verticality control device

Rotating auger cleaner

Star type auger cleaner

Hydraulic vibrator for cages

Lutz instrumentation for measuring, displaying and digital recording of the following parameters:

- drilling depth
- concrete pressure
- concrete capacity and volume
- mast inclination (two axis)

The instrument is complete with software for processing the data on a PC

Device for transmission thru mobile telephon of parameters measured by Lutz instrumentation

Kit for automatic extraction of CFA for Lutz instrumentation



Casagrande S.p.A.

Via A. Malignani, 1 - I-33074 Fontanafredda

Pordenone - Italy

Telephone (+39) 0434 9941 - Fax (+39) 0434 997009

E-mail: info@casagrandegroup.com

casagrande group

www.casagrandegroup.com