



14206 North Ohio Street
Rathdrum, Idaho 83858
[TOLL FREE] 208.687.3311
[FAX] 208.687.4153
www.bayshoresystems.com



PROUDLY MANUFACTURED IN THE USA

R 2-2014 ENG



LōDril®

E150

TR Series

LAD Series

OUR MISSION

“To improve the way holes are drilled in the construction industry and make our customers the most successful contractors in the business.”

INDEX

About BAY SHORE SYSTEMS	3
LōDril	6
LōDril SPECIFICATIONS	13
E150	14
E150 SPECIFICATIONS	19
TR Series	20
TR Series SPECIFICATIONS	27
LAD Series	28
LAD Series SPECIFICATIONS	31

Since 1978 Bay Shore Systems Has Been Dedicated to Just One Thing:

Putting the Best Foundation Equipment in the Hands of Customers.

If you're in the drilling industry, it's hard to imagine a world without Bay Shore Systems, but once upon a time there was such a world. The innovations, advancements and commitment to excellence that has characterized Bay Shore Systems for more than three decades was once just an idea — and a promise. The idea was to focus on improving processes and solving problems in the drilling industry with new and innovative equipment. The promise was to listen to customers and be responsive to their needs.



Today, the idea has taken shape in products that have revolutionized limited access and conventional foundation drilling. And the promise has been fulfilled, as Bay Shore Systems rigs are the most versatile and consistent profit producers for hundreds of happy customers.

In the process, Bay Shore Systems has become a trusted equipment resource for drilling contractors throughout the world — a finely tuned machine; capable of all the precision necessary to manufacture some of the world's finest drilling rigs and support the contractors that own them.

Built by Drillers, for Drillers

With more than 251 years of combined drilling experience, the staff at Bay Shore Systems is no stranger to the problems you face on the job every day. They've been where you are. From design engineers to technical service and sales personnel, Bay Shore people are "boots on the ground" folks. Whether it's the first turn of the auger or the last spin-off of the job, you can be sure that unmatched reliability has been carefully engineered into every Bay Shore Systems rig — by people who have sat where you're sitting and have done what you're doing.

Custom Engineering to Meet Your Specific Needs

If you have a unique set of drilling needs, Bay Shore Systems is your best choice for custom solutions. Bay Shore Systems engineers will work with you to make sure your equipment meets your job specifications.

If you get the job, Bay Shore will make sure your equipment can do the job.

Convenient Delivery, Installation and Thorough Training

When your rig is ready to work, you'll be ready too. Bay Shore can install your rig on a base machine of your choice at the Bay Shore facility, or at your location anywhere in the world. Plus, a Bay Shore technical team will train you on safe and efficient operation of your new rig. Ease of operation is a priority at Bay Shore, so you'll feel right at home with your new rig.

Never More Than a Phone Call Away

Whether it's spare parts, troubleshooting or on-site repair, Bay Shore Systems is fully committed to providing you with the service you need to keep your rig productive. That's why there is a Bay Shore technician available 24 hours a day. Common sourcing of parts means that many of the parts you need can be found in your local area. Parts are identified by manufacturer and part number in your manuals. Specialized parts are kept in inventory at Bay Shore and can often be shipped within hours.

A Growing Distributor Network

Bay Shore Systems currently has distributor relationships in many of the world's major market areas. These distributors work to provide you with more local service and support and also provide Bay Shore with the feedback necessary to continually improve products to meet your specific needs.



Under Bridges or Power Lines. Over Obstacles or On Slopes. LōDril Puts Power Where it Counts!

When innovative design, precision engineering and rugged construction come together in a single drilling tool, the result is the most versatile, high-performance workhorse in your fleet. This is the discovery drilling contractors the world over have been making since the first LōDril entered the market in 1991.

Add a LōDril to your fleet and go where your competitors can't go. Get the jobs they can't get. The flexibility and reach of an excavator mounted drilling system plus the power and low clearance advantages of a LōDril, make a winning combination that will add jobs to your schedule and profits to your bottom line.

Telescoping Kellys Get Down Deep in Low Overhead Conditions

The LōDril's telescoping kellys allow you to drill deep under severe overhead restrictions. Even in tough soil conditions the power and depth capabilities of the LōDril will

get the job done. Select from LōDrils with drilling depths from 30 ft. (9 m) to 125 ft. (38 m) and hole diameters up to an amazing 22 ft. (6.7 m).

Next time your job calls for drilling in a tight spot, it's time to call Bay Shore Systems and bring the power and versatility of a LōDril to your fleet. With LōDril models capable of matching nearly any excavator and delivering hydraulic torque from 10,000 ft.-lbs. (14 kN-m) to 110,000 ft.-lbs. (149 kN-m), you can find a LōDril that's right for your drilling operation.

In addition to easily handling the typical drilling jobs, the LōDril is at home in some of the most unfriendly drilling conditions including:

- On slopes
- Inside buildings
- Uneven or rough terrain
- Large diameter holes
- Under bridges
- Over obstacles
- Under power lines
- Over casing



LōDril DH40

Torque Ratings: Hydraulic vs Mechanical

The LōDril is a powerhouse of hydraulic torque. Comparisons between the hydraulic torque delivered by a LōDril and the mechanical torque of other rigs are often distorted when no allowances are made for the differences between hydraulic and mechanical torque. In order to get an accurate comparison of the actual performance capabilities of the two types of machines, the general rule is to divide the mechanical torque in half in order to reach an equivalent value in hydraulic torque. This is because mechanical rigs, at a normal drilling speed, say 30 RPM, are often at a torque of half the overall rating. Their full torque rating is only reached at or near 0 RPM. Obviously, most holes do not get drilled at this speed. Hydraulic rigs, on the other hand reach their rated torque between 10 and 30 RPM — speeds at which efficient production can occur.

When comparing mechanical to hydraulic machines, engine power is key. Many other drill rigs will boast very high torque ratings but without enough engine power they achieve this torque at very low drill speeds, many times below 10 RPM. With a LōDril fit to a specified size excavator base you will have working drill speeds as high as 60 RPM. Plus, hydraulic rigs are more reliable, require less maintenance and are more forgiving of operator errors and unforeseen drilling conditions.

When you're making a critical equipment decision you

need to have the correct information in order to properly evaluate your options. More details can be found on the Bay Shore Systems website at www.BayShoreSystems.com

Custom Engineered Solutions for Your Exact Drilling Needs

If you're looking to add to your fleet of drilling equipment, chances are pretty good that you have a specific job or jobs in mind. This is where the versatility of the LōDril gives you a tremendous advantage. Bay Shore Systems can engineer your LōDril to meet the requirements of a specific job. Your LōDril will be manufactured to meet your specs for even the most difficult drilling environments. But, at the same time, your LōDril gives you the flexibility to work in nearly every other drilling condition you normally face. You may start out with one job in mind for your LōDril, but over and over again the LōDril has become the daily drill of choice for drilling contractors everywhere.

Use a New or Existing Excavator — The Ultimate Flexibility

You can purchase a new excavator, or your LōDril can be mounted on an excavator already in your fleet giving you an opportunity to extend the life of a valuable resource and reduce the impact of your total investment on your bottom line. Either way, your LōDril will be engineered for the base machine that makes the most sense for you.



LōDril DH20



LōDril DH60



LōDril DH20

We listen.

"Since purchasing our LōDril from Bay Shore Systems it has not stopped working. We introduced this rig to our fleet of drilling equipment and it has made us a more diversified drilled shaft contractor. If you want to be 'wowed' then you need to add a LōDril from Bay Shore to your fleet." – Gene E. Sheedy, P.E. President, Midwest Drilling Foundations & Engineering, Inc.

LōDril DH30

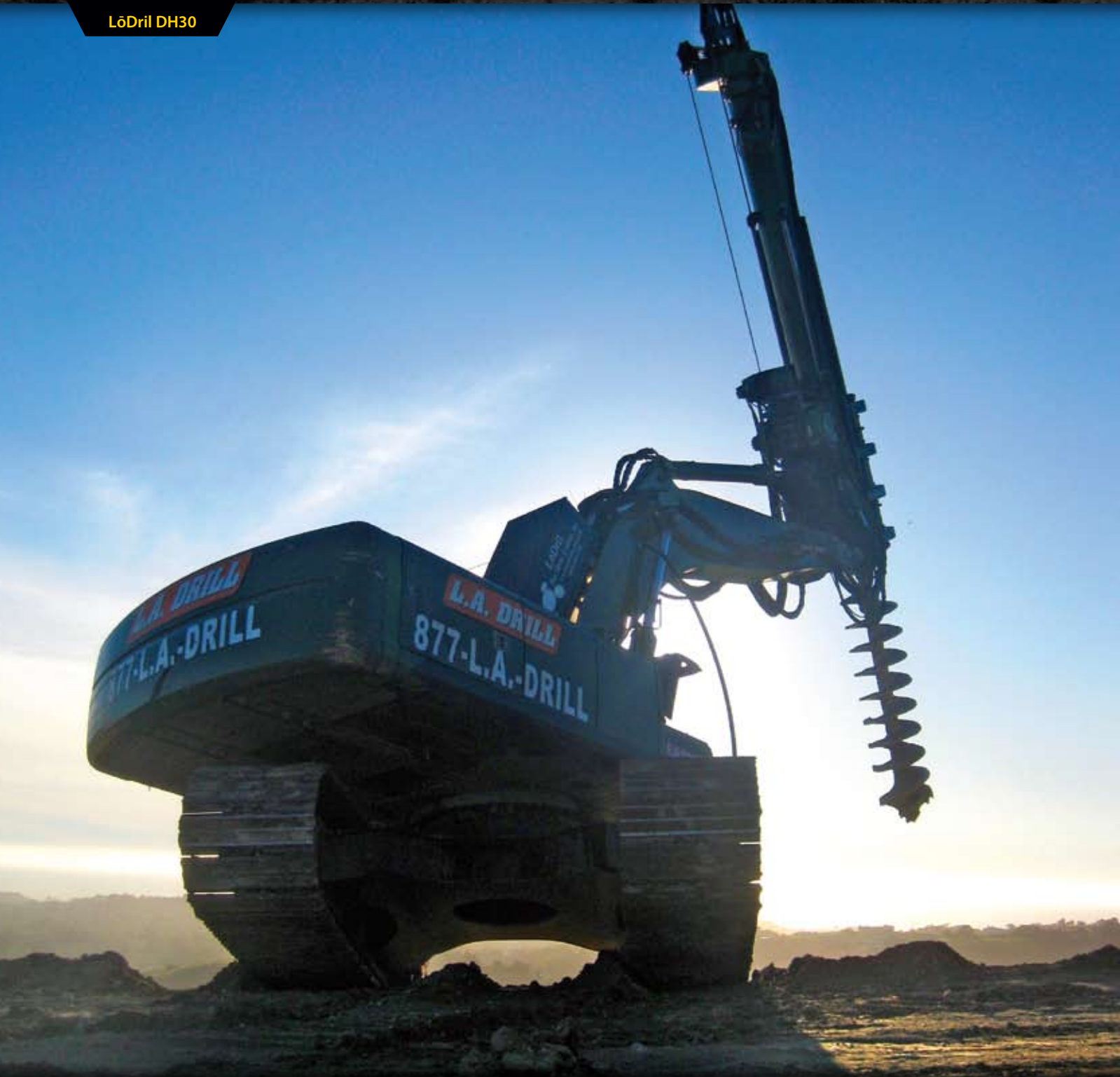

LōDril DH30



LōDril DH15



LōDril DH20



We listen.

"Our LōDril is one of many rigs in our fleet of drilling equipment and year after year it continues to work the most amount of hours out of any rig in our fleet. The machine is incredibly versatile." – Martin Griffiths Piling Plant & Drilling Equipment Manager, Fletcher Construction Company, New Zealand

Add These Options to Make Your LōDril Work Even Harder

- **Kelly Bar Upgrades**
With three grades of kelly bar material to choose from, you can pick the best material for your budget or your job specific needs.
- **Kelly Winch Upgrade**
On most models you can upgrade to a larger kelly winch for maximum hoisting capability.
- **Service Winch**
Add a service winch to make tool changes quick and convenient.
- **Round Self-locking Kellys**
Increase your crowd force in hard drilling conditions and boost your production on tough drilling jobs.
- **Reaction Jack**
Adding a reaction jack in combination with round, self-locking kelly bars will give your LōDril the ability to handle some of the toughest rock.
- **Power Line Detector**
Sounds an alarm when you come close to live power lines.
- **Boom Modification**
Maximize the size of the LōDril you can put on a smaller excavator.
- **Telescoping Boom**
Work out further beyond the tracks, or work closer in or just increase your crowd force and flexibility over the hole.
- **Quick Disconnect**
Easily remove the LōDril from the excavator.
- **Custom Options**
Need more options? Bay Shore engineers are ready to hear your requests for custom options and will do everything possible to bring them to you.



LōDril DH100



LōDril DH100

LōDril Specifications

Specification	Units	DH15	DH20	DH30	DH40	DH60	DH80	DH100
Rotary Torque ¹	ft-lbs	15,000	21,500	30,000	43,000	65,000	84,000	110,000
	kN-m	20	29	40	58	88	114	149
Max. Kelly Winch Line Pull (bare drum)	lbs	8,000	12,000	18,000	25,000*	30,000*	30,000	40,000*
	kN	35	53	80	111*	133*	133	178*
Hole Diameter ²	in	36	48	60	84	108	132	144
	mm	900	1,200	1,500	2,100	2,700	3,300	3,600
Drill Speed Range ³ low/high/spin off	rpm	30/60/100	30/60/100	30/60/100	30/60/100	30/60/100	20/50/100	20/50/100
Hole Depth ⁴	ft	30-80	30-100	30-100	30-100	40-125	40-100	40-80
	m	9-24	9-30	9-30	9-30	12-38	12-30	12-24
Attachment Height ⁴	ft	9-21	10-21	16-26	14-26	17-32	22-33	22-33
	m	2.7-6.4	3.0-6.4	4.9-8.0	4.3-8.0	5.2-9.8	6.7-10.0	6.7-10.0
Excavator Class x 1000 ⁵	lbs	16-35	35-50	50-65	70-95	75-100	100-150	100-150
	kg	7-15	15-22	22-29	32-43	34-45	45-68	45-68

¹ Running Torque at low drill speed

² Dependent on ground conditions, tooling and operation

³ Dependent on excavator

⁴ LōDril configuration specific

⁵ Excavator modifications may be required

* With upgrade

Check our website www.bayshoresystems.com for the latest specifications

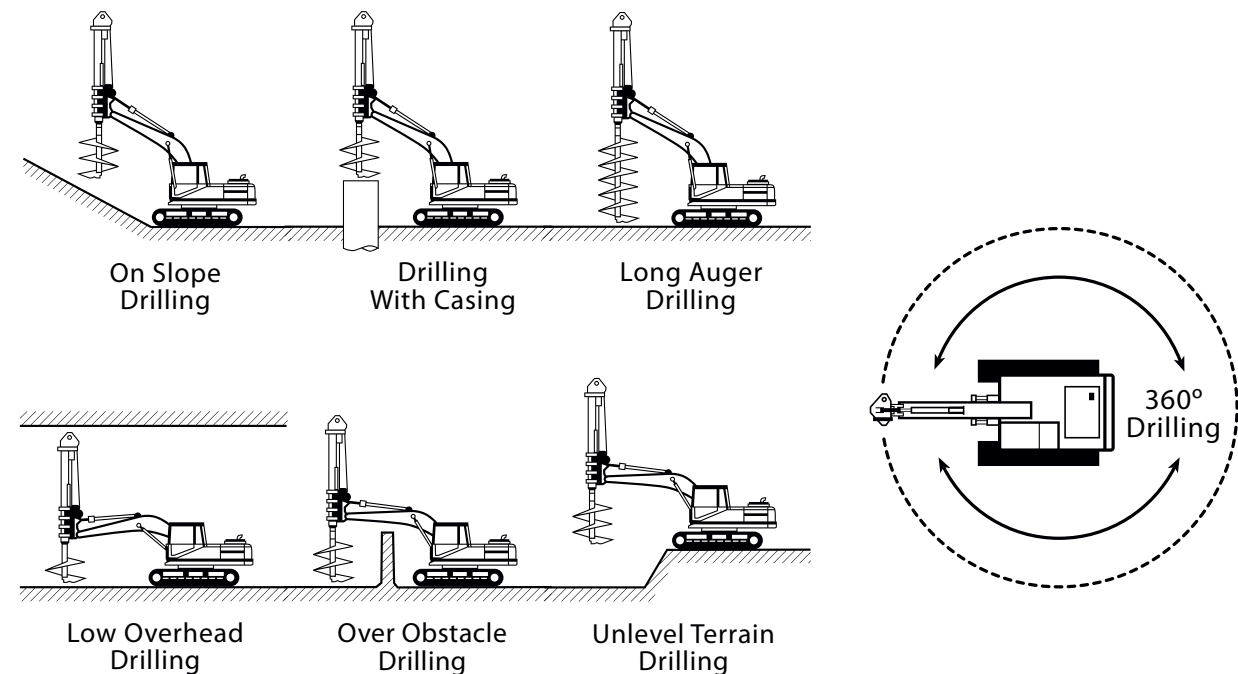

"We have been working with Bay Shore since 2004 and own two LōDrils. They are very versatile and solve countless problems in our construction business. Many years of work experience have shown that the LōDril and Bay Shore Systems have played a key role in our business success." – **Dmitriy Mokov**, Yugstroymechanizatsia, Sochi, Russia

The E150 Euro-Style Rig: Changing the Conversation

There are plenty of high-profile drill rigs on the market today. There are also plenty of complaints from drilling companies to go along with them. But the E150 is changing the complaints into compliments. Here's how Bay Shore Systems is changing the conversation:

Get Down the Road in One Load

Bay Shore engineers created the E150 to solve a series of major problems with traditional rigs. One major issue addressed was transport. Having a rig that, without disassembly, can fit completely on one trailer and still meet standard height limits would be a major advantage for drilling companies. The cost savings in transport from job to job would be tremendous. Bay Shore engineers accepted that challenge and the result is the only rig in its class that will fit on one trailer and will come in under the 11'6" (3.5 m) height limit. Or, if your transportation needs require it, disassembly for transport is done quickly and easily. Either way, you can finally have a rig that will save you time and money before it even arrives on the job site.

Parts Now!

If you're like every other drilling company, having fast access to replacement parts is a key issue. When you're

on a job—or prepping for a job—you need access to a spare parts inventory that won't take weeks to deliver. The E150 is built in the USA with common source parts. Most replacement parts can be sourced quickly from your local suppliers. Specialized parts are inventoried at Bay Shore Systems and can usually be shipped within 24 hours of ordering. When you're not drilling, you're not making a profit. If your rig is down, you want your parts now, not weeks from now. That's one important difference between the E150 and other rigs in its class. You need parts? **You get parts, fast.**

Powerful Cummins Diesel Engine

The power plant driving the E150 is a clean running, 11-liter, Cummins diesel engine delivering 360-horsepower (270 kW). This power plant will give you years of trouble free service even under the most rugged conditions. Designed for easy access maintenance, the E150 engine is the highest-powered engine in its class and will be the reliable heartbeat for a new profit center in your drilling fleet.



We listen.

"Your customer service is second to none. I have never worked with another company that was as accommodating as Bay Shore Systems."

— Wayne Seppelt, Tri-State Drilling



Increased Mast Strength Prevents Buckling

The specially designed mast uses high-strength alloy steel and is engineered to provide a working tool that resists buckling. Rugged materials combined with a unique design result in a mast that can withstand full cylinder tilt up force. The mast will not be damaged if an obstruction is encountered during tilt-up.

Increased Rigidity Means Straighter Holes

The outer kelly guide of the E150 remains above the rotary. That means that the kelly bar system maintains two extended points for stability during the entire drilling process. This extra rigidity allows the E150 to produce straighter holes, even in tough conditions. Plus, additional kelly bar support reduces wear and increases the life of kelly bars.

Dedicated Carrier

From the tracks up, the carrier is designed for use as a drill rig. That means that the entire rig operates as one unit and has been designed to properly distribute weight and power. When building a rig of this class, it is critical that every element be engineered for exactly one purpose—to give you unparalleled performance. There are no structural or system modifications because no conversion has taken place. It was born to drill.

Easily Work Over Casing

The E150 has all the power you need to not only get you down to depth in tough soil conditions, but also to handle casing when you need it. Unlike other rigs where casing is an afterthought, the E150 is casing capable from the very outset. So, if you're often in drilling environments where casing is required, the E150 is a perfect choice to push that casing into the ground and help your bottom line.

Kelly Bar Options

The E150 can handle three different kelly bar set options. Three-element sets range from 60 ft. (18 m) to 100 ft. (30 m) and four element sets go from 100 ft. (30 m) to 150 ft. (45 m). Plus, the replaceable drive sleeve can be built to fit other manufacturer's kelly bars. With the proper drive sleeve and other minor modifications, your E150 can make use of idle bar sets from most any other manufacturer.

Round Locking Kelly's

Another significant advantage of the E150 is that its standard 4-element kelly bars are the specially designed Bay Shore Systems round, locking kellys. Round, locking kelly bars are a huge boost to productivity in tough drilling conditions as the bars can be locked into position by the operator while sitting safely in the cab, away from the hole.



E150

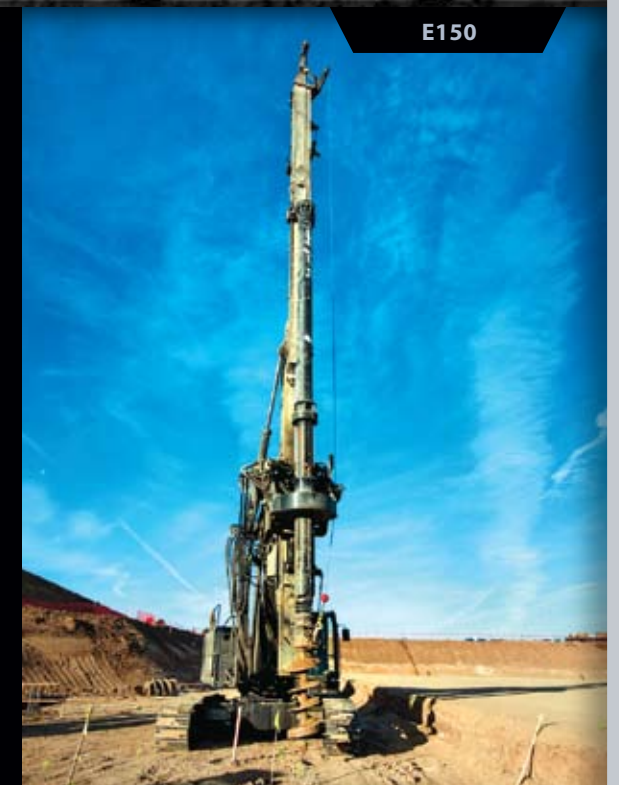

E150



E150

We listen.

"For starters, your trouble-shooting over the phone is excellent. We had a service technician come and make some minor repairs and adjustments not too long ago. He was very professional, helpful and completed his tasks much faster than we expected." – Matt Elder, Atkinson Construction



Expanding Tracks

The E150's extra wide tracks allow you to have the stable platform necessary to provide a solid base for drilling shafts that are true and precise. But that same width is going to cause trouble when you're trailering your rig and moving to the next job. That's why the E150 is equipped with tracks that will expand and retract as needed for stability or transport.

Self-setting Counterweights

When you need to add or remove your counterweight on the job site, the E150 makes this task simple. A specially designed hydraulic system removes the counterweight and lowers it to the ground. When you want to restore it, the same system will pick it up and place it in position on the rig, making alignment a breeze. This eliminates the need for additional equipment to handle the movement of the counterweight.

Ease of Operation Increases Productivity

The E150 is easy to operate. Familiar two-joystick controls handle the major functions of the rig. The cab is extra-roomy and comfortable compared to other rigs in its class and features heat and A/C, reducing operator fatigue. Your operators will love working with the E150 and will quickly become adept at managing all functions

Simple Maintenance and Troubleshooting

There is a place and a purpose for high-tech electronics in a drill rig, but when technology glitches start to increase downtime, it's time to re-think. That's exactly what Bay Shore has done with the E150. Computers and microprocessors don't control the drill. You do. Everything is hydraulic. So, when something needs attention, you'll get more done with a wrench than a laptop. That will save you time, money and considerable frustration.

Legendary Customer Service

When it comes to understanding you and building a rig that meets your needs—and then giving you the ultimate in customer service after the sale—the staff at Bay Shore Systems has no equal. Go ahead. Ask anyone. Bay Shore Systems is well known for both building great rigs and taking good care of customers. It's been their firm commitment since 1978.

E150 Specifications

Specification	Units	E150
Rotary Torque	ft-lbs	150,000
	kN-m	200
Max. Kelly Winch Line Pull (Bare Drum)	lbs	50,000
	kN	220
Crowd/Retract Force	lbs	50,000/45,000
	kN	220/200
Crowd Stroke	ft	18' 4"
	m	5.6
Hole Diameter	in	72
	mm	1,800
Drill Speed Range Low/High/Spinoff	RPM	10/30/100
Max. Hole Depth	ft	150
	m	45
Attachment Height (Drilling Position)	ft	68
	m	21
Base Machine	HP	360
	kW	268
Undercarriage Transport Drill Mode	ft	10/15
	m	3/4.6
Transport Height	ft	11' 5"
	m	3.5
Transport Weight	lbs	135,000
	kg	62,000

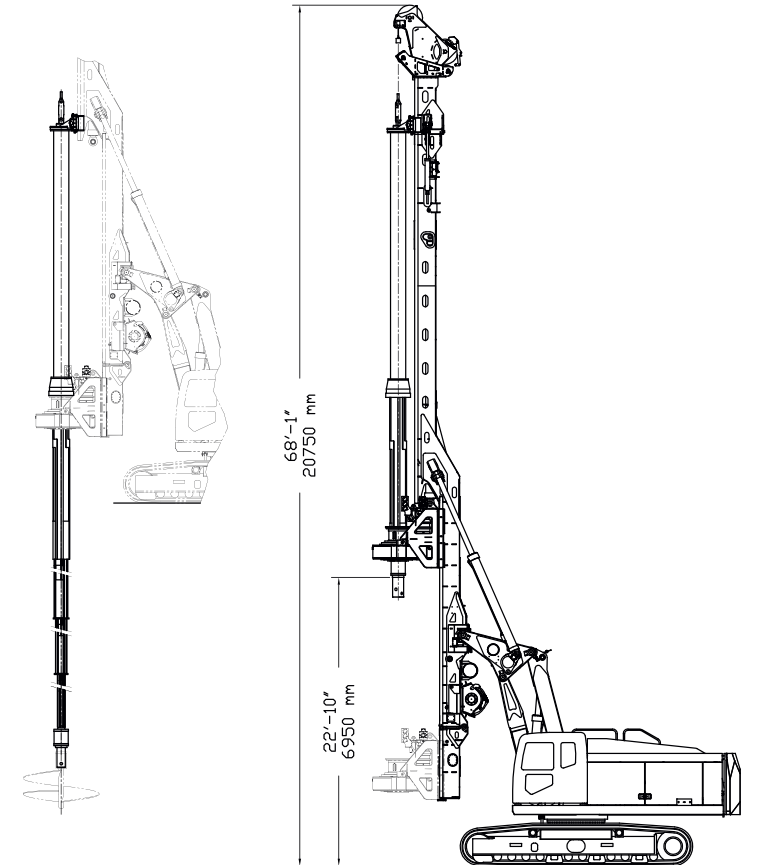

Transport Weight Breakdown

Specification	Units	E150
Kelly Bar	lbs	13,000
	kgs	5,900
Counter Weight	lbs	17,500
	kgs	8,000
Rotary and Sled	lbs	9,000
	kgs	4,100
Disassembled Weight	lbs	95,500
	kgs	44,000

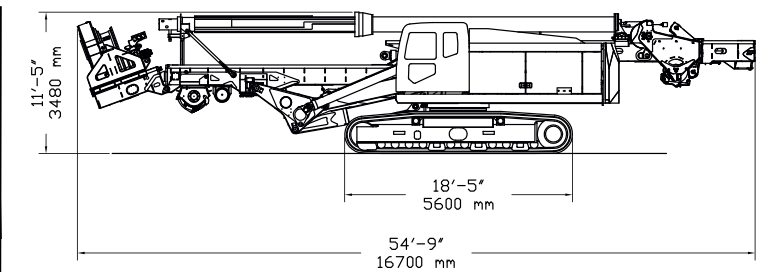

The Bay Shore Systems TR Series: Truck, Track or Excavator Mounted Drills Bring Power, Depth and More Flexibility to Your Drilling Fleet

From Power Line Foundations to Residential Footings, the TR Series is Your Perfect Solution

As a company already responsible for some of the most popular innovations in the drilling industry, Bay Shore Systems has compiled significant data and feedback from drilling contractors to develop the TR Series of drill rigs. Truly the “driller’s drill rig” the TR Series has been carefully engineered by Bay Shore for high performance, reliability and productivity.

100% Hydraulic Rotary Means More Up Time and Increased Production

Unlike old-fashioned mechanical rigs, the TR Series is one hundred percent hydraulic. It has no drive line, torque

converter or transmission, and requires no shifting. Operation is smooth and drilling speed is infinitely variable. This will increase your production not only from hole to hole, but over the long term as fewer mechanical parts means less potential breakdowns and increased output.

Truck Mounted PTO Powered Option Reduces Environmental Impacts and Expenses

In the truck mounted TR, the horsepower necessary to operate the drill is created by the main engine. This relieves you of the burden of additional environmental impact and other associated costs of running a second engine. Plus, since your rig is lighter than alternative equipment, over the road permitting in many cases will not be necessary. The TR Series is tough enough to get the hard jobs, but



TR Series

TRUCK, TRACK OR EXCAVATOR

TR Series

easy enough on expenses to yield better profit potential on every hole. The TR Series rigs are unmatched in long term return on investment.

Upper Engines When You Need Them

While many of our truck mounted TR rigs don't have upper engines, your rig can be equipped with an upper engine matched to your power requirements. We have many options from which to select the engine that will give you just the right edge for increased power and productivity.

Comfortable, Easy Operation

Two simple joystick controls operate the full functionality of the rig. These ergonomic controls are similar to what the operator would use on an excavator. They are easy to learn and, unlike archaic mechanical controls, can be operated for long periods without fatigue. And, the TR Series offers operator placement ideal for maximum working visibility.

Winch management is another added feature of the TR Series. The fully integrated kelly winch requires no extra operator attention or separate controls helping to avoid birdnesting or breaking cables, increase efficiency and boost production.

You Won't Sacrifice Depth or Torque with the TR Series

This robust series of rigs boasts hydraulic torque from

21,500 ft.-lbs. (29 kN-m) to an unstoppable 200,000 ft.-lbs. (271 kN-m). Not only will your TR rig bring high torque to your job, but you'll be able to use that power to get down as deep as 80 ft. (24 m)*.

Get Your TR on Tracks for High Production Requirements

When the pressure is on, the track mounted TR will help get you into high gear. With no outriggers to pull up and reset on every hole, this high efficiency rig will have you busting through your daily production goals time after time. Pick from multiple engine options to make sure you have exactly the right power source you need to cut through the toughest conditions and get the job done on time.

The track mounted option also allows you to customize your base platform for:

- Hydraulic hose reels
- Onboard compressor
- Water storage
- Expanded tool and equipment storage

*Deeper configurations are available.



We listen.

"Due to my positive experience with the DH60 LoDril I own, I have just purchased a new TR40 truck rig. Having a truck mounted drill rig in my fleet will greatly add to my drilling capability and I know I can count on Bay Shore to stand beside me and their equipment." – Steve Usherwood, Southwest Concrete Construction



www.bayshoresystems.com

TR Series

TRUCK, TRACK OR EXCAVATOR

TR Series

A TR on an Excavator — The Ultimate in Flexibility

When your TR is mounted on an excavator, you'll have the full range of reach and pivot capabilities that come with an excavator. Plus, a full boom tip will give you the extra reach you need to get over the hole when your competition can't. And, parallelogram boom options can give you all that in a compact package that makes maneuvering and transportation a breeze. Just one more way you'll have the flexibility to get the job—and get the job done!

An Extra Level of Precision

The separate side tilt and mast tilt functions on most TR rigs will help you to set your rig quickly and precisely, adding to efficient production hole after hole.

Dry Kelly Bar. Simple. Clean. Green.

Whether your TR is configured with a single element or multiple elements you will not need to worry about an old fashioned leaking kelly system that constantly needs maintenance. A TR dry kelly system will give you the capability of a wet stick rig with reliability and confidence.

Isn't it About Time?

If you're tired of fighting with drilling equipment that hasn't changed in the last 50 years, then you need to

look into the TR Series from Bay Shore Systems. Get all the advantage of new technology from a company with decades of drilling equipment experience and a history of innovation. Your TR series rig will give you fast production and great competitive advantages for jobs like these:

- Rock drilling
- Battered or raked holes
- Typical foundation drilling
- Power line and utility foundations



We listen.

"We regularly drill 4' and 6' diameter holes under slurry in very sticky conditions. The TR40 has been a solid choice for our application. The overhead powerline detector is another added benefit this rig has to keep our workers safe."

— Eldon Sivley, North Houston Pole Company (A Quanta Company)



www.bayshoresystems.com

Custom Options to Make Your TR Series Rig Work for You

- **Truck, Track or Excavator Mounted**
Whatever option suits your needs, your rig can be mounted to any of these three base units.
- **Kelly Bar Upgrades**
With three grades of kelly bar material to choose from, you can pick the best material for your budget or your job specific needs.
- **Square Kelly or Round Locking Kelly**
Traditional square kelly or Bay Shore Systems' unique round locking kelly design.
- **Kelly Winch Upgrades**
On most models you can upgrade to a larger kelly winch for maximum hoisting capability.
- **Water Tank**
Onboard water storage.
- **Tool Boxes**
Convenient, secure storage for your hand tools and other equipment.
- **Umbrella or Cab**
Protect yourself from the elements and improve your production under adverse weather conditions.
- **Power Line Detector**
Sounds an alarm when you come close to live power lines.
- **Pressure Washer**
Easily remove excess dirt and debris from your rig.
- **Utility Version**
Special options for use in the utility industry including: Single element Kelly, increased side tilt and pole grab.
- **Custom Options**
Need more options? Bay Shore engineers are ready to hear your requests for custom options and will do everything possible to bring them to you.



TR30



TR40

TR Specifications

Specification	Units	TR20	TR30	TR45	TR70	TR100	TR150	TR200
Max. Rotary Torque	ft-lbs	21,500	43,000*	43,000	80,000*	100,000	150,000	200,000
	kN-m	29	58*	58	108*	135	200	270
Max. Kelly Winch Line Pull (bare drum)	lbs	12,000	18,000	25,000	30,000*	30,000	40,000	40,000
	kN	53	80	111	133*	133	178	178
Hole Diameter ¹	in	48	60	84	108	132	168	168
	mm	1,200	1,500	2,100	2,700	3,300	4,200	4,200
Drill Speed Range ²	RPM	30/60/100	40/100/130*	30/60/100	25/50/100	10/30/100	10/30/100	10/30/100
Max. Hole Depth ³	ft	80	60	80	80	80	80	80
	m	24	18	24	24	24	24	24
Truck GVRW x 1000	lbs	50	60	60	79	N/A	N/A	N/A
	kg	22.5	27	27	35	N/A	N/A	N/A
Truck GVW x 1000	lbs	45	50	55	66	N/A	N/A	N/A
	kg	20	22.5	25	30	N/A	N/A	N/A
Excavator Weight ⁴ Class x 1000	lbs	35-50	50-65	50-65	70-95	75-100	75-100	100-130
	kg	15-22	22-29	22-29	32-43	34-45	34-45	45-65
Truck Mount Max. PTO Power	HP	200	200	200	200	N/A	N/A	N/A
	kW	149	149	149	149	N/A	N/A	N/A
Max. HPU Engine Power	HP	180*	250*	250*	250	300	350	400
	kW	135*	185*	185*	185	220	260	300

¹ Dependent on ground conditions, tooling and operation

² Dependent on hydraulic system

³ Dependent on configuration

⁴ Excavator modifications may be required or anticipated

* With upgrade

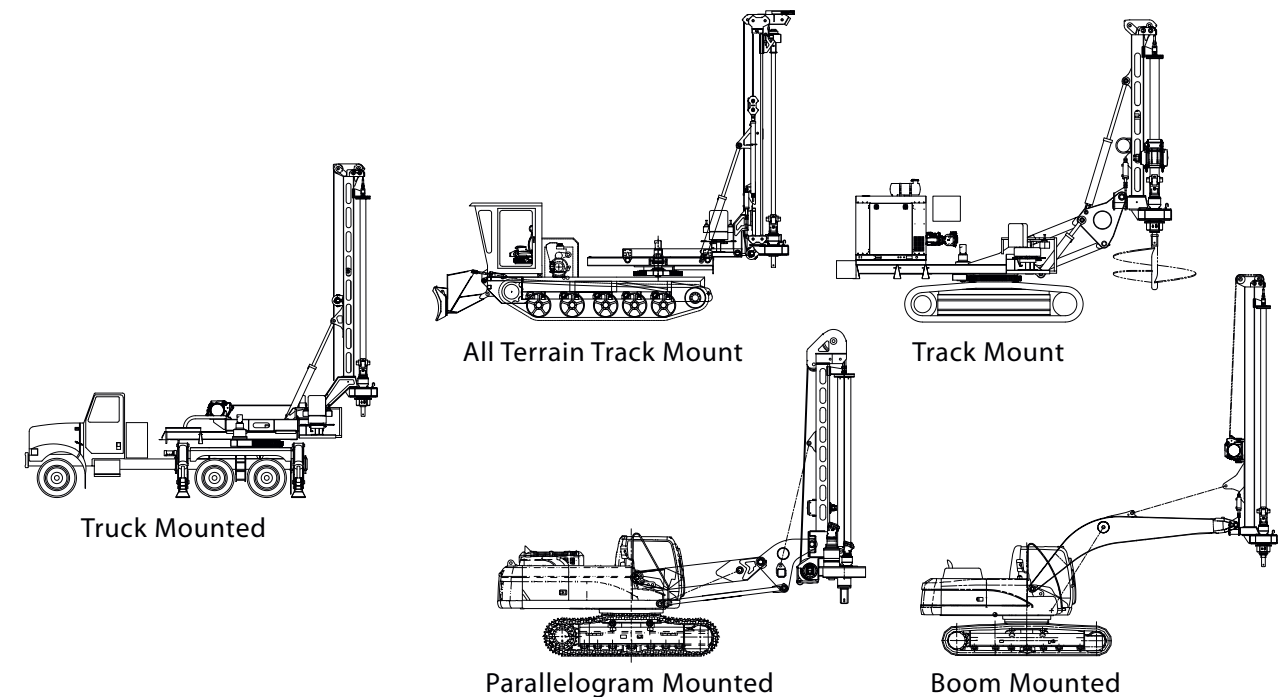

"Bay Shore approached us for our input on designing their new TR line and we were the first to use their prototype on one of our job sites for about a month. The rig performed so well we quickly forgot it was a prototype!" – Scott Carr, Wilson Construction

The LAD Series Drills from Bay Shore Systems Will Get You Into a Tight Spot — And Out Again

From a company who pioneered limited access drilling equipment comes a collection of drills on a whole different scale. These small drills are specially designed to bring deep drilling capabilities to severely restricted access jobs.

Go Where No One Else Can Go. Get the Jobs No One Else Can Get.

That's what you'll do, day after day with the LAD Series of drills from Bay Shore Systems. With attachment heights as short as 6 ft. 6 in. (2 m) and drill depths as deep as 60 ft. (18 m), there is nothing small about these rigs. The smallest LAD Series drill can even be moved around on site by hand. A wide torque range will give you the capability of drilling up to a 48 in. (1,200 mm) hole in some very challenging conditions.

Small Drills Consistently Making Big Profits for Customers

If it were always easy anybody could do it. But drilling jobs are not always easy. That's when Bay Shore customers have an advantage. When you're faced with an extremely difficult access drilling situation, the LAD Series rigs will make a hero out of you. With torque from 800 ft.-lbs. (1,085 kN-m) to 10,000 ft.-lbs. (13,600 kN-m), your LAD Series drill will make quick work of even tough soil conditions and is ideal for residential foundations, elevator shafts, engineered landscape projects or other severely restricted access drilling conditions.



LAD80

We listen.

"Viking Drillers owns a fleet of Bay Shore equipment but the LAD80 is probably the most profitable drill rig we own. It is very compact and powerful solving a lot of problems our customers need us to solve." – Kevin Montoya, Viking Drillers



Use Your Bay Shore LAD Rig to Crush the Competition

There are many other limited access drills on the market today. Having a rig that separates you from your competition is key in getting these extreme access jobs done on time and on budget. The LAD line offers drilling speeds as high as 60 RPM where many competitive rigs will peak out between 20-30 RPM.

Customization is Still King

As with the larger Bay Shore Systems drilling equipment, these mini-drills can be customized to suit your drilling conditions as well as the excavator on which you want the attachment mounted.

So, don't let the small size fool you. LAD Series rigs are consistent performers for their owners. Why don't you ask your Bay Shore Systems rep about one? Or, look at them online at www.BayShoreSystems.com.



LAD80



LAD100

LAD Series Specifications

Specification	Units	LAD50	LAD80	LAD100	LAD 300
Rotary Torque	ft-lbs	5,000	8,000	10,000	30,000
	kN-m	6.8	11	14	40
Max. Kelly Winch Line Pull (bare drum)	lbs	5,000	5,000	8,000	18,000*
	kN	22	22	35	80*
Hole Diameter ¹	in	32	36	42	60
	mm	750	900	1,050	1,500
Drill Speed Range ²	RPM	20/60/100	20/50/90	20/50/100	25/60/100
Max. Hole Depth ³	ft	40	50	60	100
	m	12	15	18	30
Attachment Height ³	ft	8	6.5	8	15
	m	2.4	2	2.4	4.6
Excavator Weight Class x 1000 ⁴	lbs	12-16	16-29	18-31	35-50
	kg	5.5-7	7-13	8-15	15-22

¹ Dependent on ground conditions, tooling and operation

² Dependent on hydraulic system

³ Dependent on configuration

⁴ Excavator modifications may be required or anticipated

* With upgrade

Notes:

"We own a LAD80 along with other limited access equipment from Bay Shore Systems. It is amazing what you can do with a small rig along with a good operator and tool. Extreme limited access work has been a large part of our business and Bay Shore equipment is an excellent choice." – Stanley Phifer, Wylie Drilling