



Machinery // Product range

MÜLLER Vibrator technology.



ThyssenKrupp Bautechnik



ThyssenKrupp



Contents



- 4 MÜLLER Vibrators
- 5 Parameters, equipment selection and operating principle
- 8 MÜLLER Vibrators H-series
- 9 MÜLLER Vibrators HHF-series
- 10 MÜLLER Vibrators HFV-series
- 11 MÜLLER Excavator-mounted vibrators
- 14 MÜLLER Power packs
- 15 MÜLLER Leader-mounted vibrators
- 16 MÜLLER Drill drives
- 17 MÜLLER Clamping devices
- 18 MÜLLER Data acquisition
- 19 MÜLLER Accessories
- 21 MÜLLER Special equipment

MÜLLER Vibrators.

Proven power “made in Germany”.

MÜLLER vibrators have a proven track record in civil engineering stretching back more than 50 years. As leading-edge vibratory products they meet all market requirements. Suitable for a wide range of applications, their reliability and constant development make them a relevant market factor.



Parameters, equipment selection and operating principle. Ensuring top performance.

Choosing the right machine is crucial for the economic and technical success of vibratory driving. In order to find the most suitable equipment, we offer our customers individual support that takes into account all relevant factors, i.e. the site conditions plus the geological and engineering requirements.

Parameters

Selecting a suitable vibrator essentially depends on the size and weight of the pile section, the embedment depth and the type of soil. Basically, the centrifugal force and the amplitude must be chosen in such a way that the skin friction and tip resistance between the pile section and the surrounding soil can be overcome.

Equipment selection

The chart below helps users to select the right vibrator or determine the centrifugal force required depending on soil conditions, pile weight and driving depth.

The use of additional equipment, e.g. water-jetting or pre-drilling units, can help to achieve much better driving performance with the same size of unit or centrifugal force of the vibrator.

The power pack must be powerful enough to generate the moment needed to maintain the centrifugal force of the vibrator, even in difficult ground. The drive output should be 2–3 kW for every 10 kN of centrifugal force.

Our advisers use numerical simulation software for selecting equipment to suit the soil parameters and pile section data exactly.

Equipment selection chart

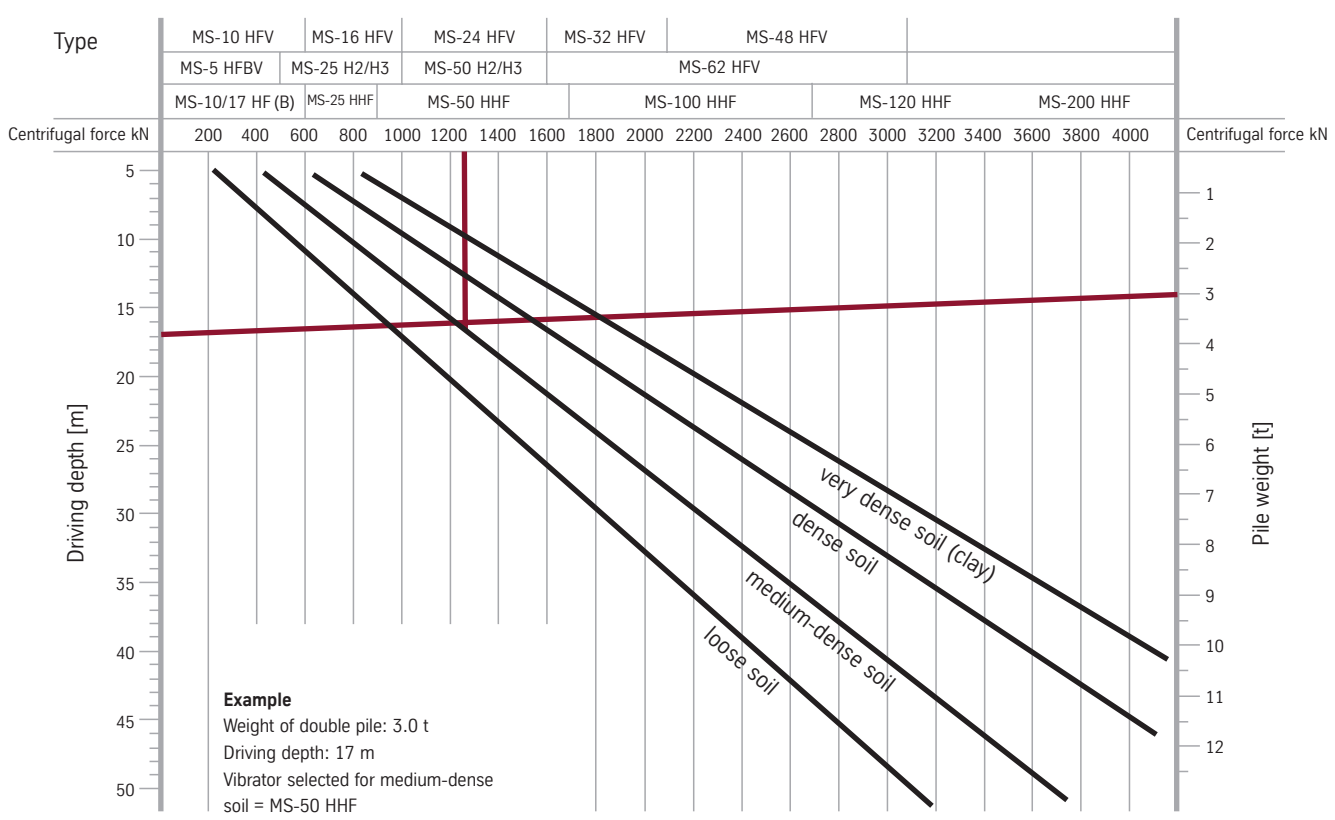

Parameters, equipment selection and operating principle. Ensuring top performance.

Operating principle of Müller vibrators (typical design)

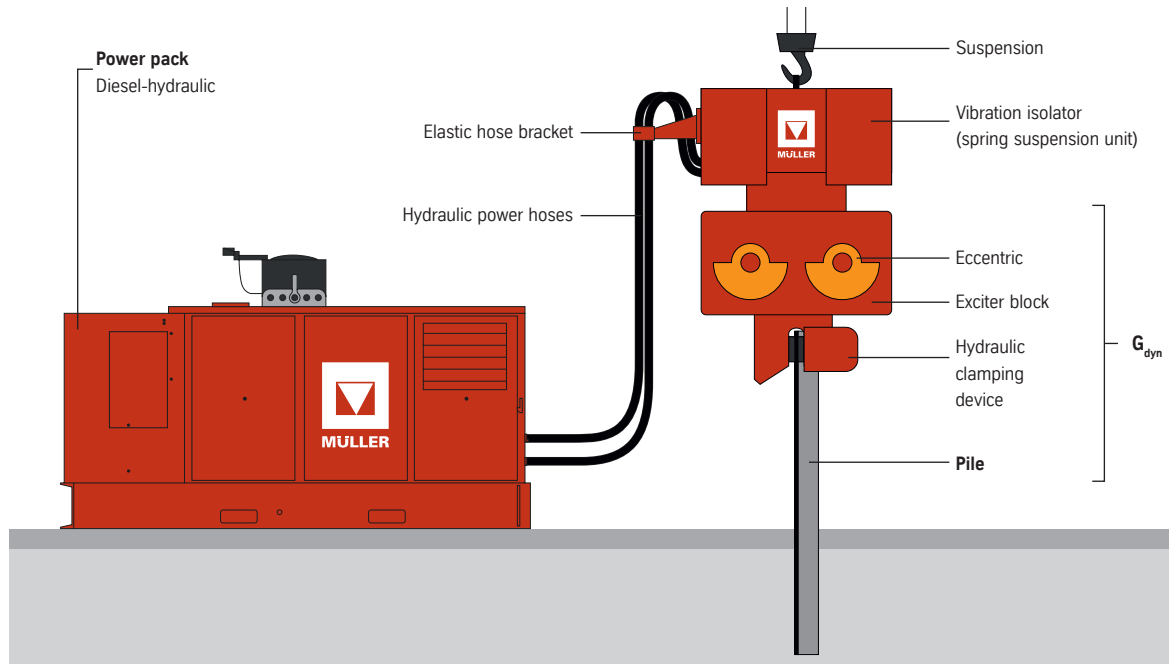

Key vibration technology data

Eccentric moment M [kgm]

$$M = G \cdot r$$

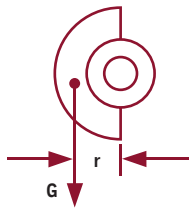

The eccentric moment is the measure of unbalance. As a determining factor for amplitude it is a key parameter for driving operations.

Total amplitude S [m]

$$S = 2s = \frac{2 \cdot M_{\text{stat}} \text{ [kgm]}}{\sum G_{\text{dyn}} \text{ [kg]}}$$

Together with centrifugal force, amplitude is a measure of driving performance. A large "stroke" and high "impact force" ensure good driving progress. When driving and extracting in cohesive soils, the elastic connection between pile and soil can only be broken if the amplitude is high enough.

Speed (Frequency) n [rpm]

The speed dictates the vibration frequency of the system. The vibrations are transferred via the pile to the surrounding soil, significantly reducing the surface friction between pile and soil. High frequencies counter the unwanted spread of vibrations in the soil.

Acceleration a [m/sec²]

$$a = s \cdot \omega^2 \quad \text{with} \quad \omega = \pi \cdot \frac{n}{30}$$

Transmission of the pile acceleration to the surrounding soil causes the displacement of the grain structure and reduces grain friction and soil resistance. Acceleration is expressed as the ratio of acceleration of the vibrator to gravity:

Centrifugal force

$$F = M \cdot \omega^2$$

$$F = [\text{N}] \quad F = M \left(\pi \cdot \frac{n}{30} \right)^2$$

The centrifugal force must be high enough to overcome surface friction between pile and soil. Centrifugal force plays a major part in reducing surface friction and provides impact force to overcome tip resistance.

$$\eta = \frac{a}{g} \quad \text{This ratio corresponds to:} \quad \eta = \frac{F \cdot 10^{-1}}{G_{\text{dyn}}}$$

The value can lie between 10 and 30.

MÜLLER H-, HHF- or HFV-series vibrators.

The right choice for every application.

The H series is the “workhorse” of vibration technology. Their robust yet simple design enables these units to be used wherever there are no restrictions on the propagation of vibrations in the soil.

With an eccentric moment that can be adapted to the soil conditions, the HHF series is ideal for applications with changing geological conditions. The largest units of this series are suitable for driving even the heaviest sheet piles into dense, compact soils.

The eccentrics can be adjusted during driving, and so the HFV series is ideal wherever maximum restrictions on the propagation of vibrations in the soil apply, e.g. working directly adjacent to existing buildings or in urban areas. These units avoid resonant vibrations during starting and stopping and also allow the amplitude to be optimised during driving to suit the ground conditions.

Principle of resonance-free starting and stopping

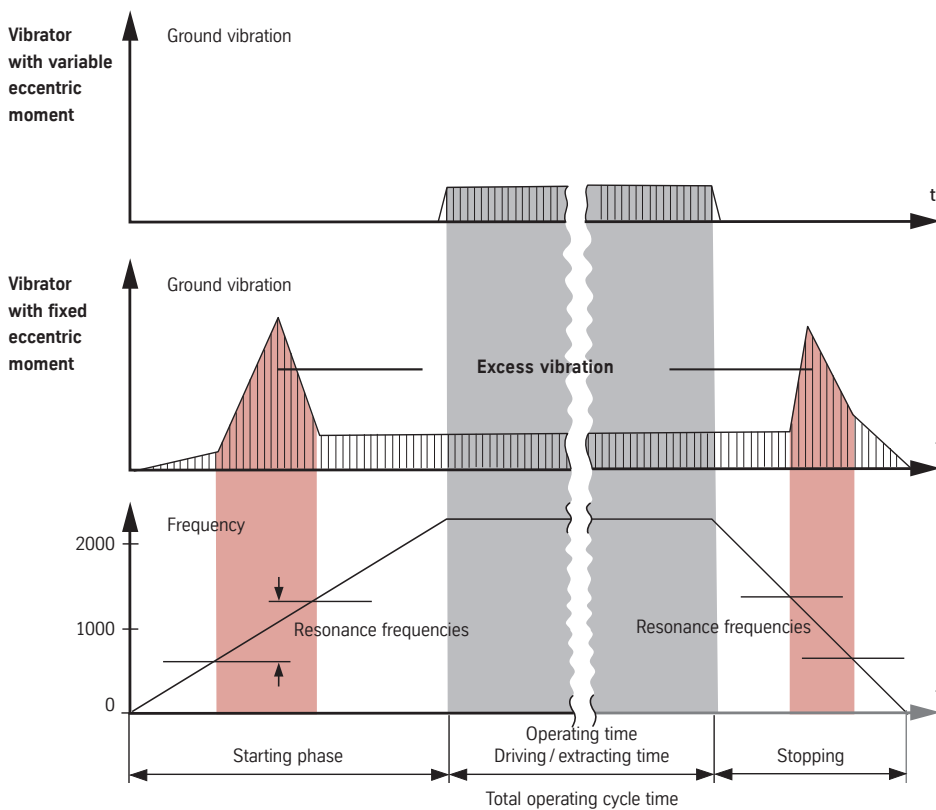

MÜLLER Vibrators H-series.

With fixed eccentric moment.

Müller vibrators with constant amplitude – straightforward to use and robust. That is the foundation for good results in moderately difficult driving conditions. These vibrators are fitted with eccentrics that generate a fixed eccentric moment. With force-feed lubrication and oil cooling, this series is equipped for applications in extreme climatic conditions.

Applications

- Soils with light to moderately difficult driving conditions
- Driving and extracting tubular piles
- Also in extreme climatic conditions

Advantages

- Extremely robust machine design
- Easy handling and easy adjustment of clamping devices

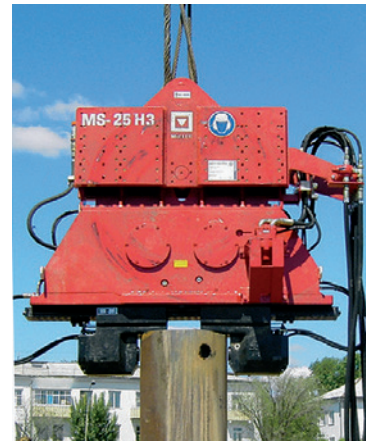

Type			MS-25 H3	MS-35 H3	MS-50 H3	MS-65 H3
Centrifugal force	F (max.)	kN	774	834	1430	1670
Eccentric moment	M stat	kgm	25	32,5	50	65
Speed	n (max.)	rpm	1680	1530	1615	1530
Frequency	f (max.)	Hz	28.0	25.5	26.9	25.5
Pulling force	F pull (max.)	kN	400	400	500	500
Weight (dynamic)	without clamping device	kg	2550	2660	3820	4200
Weight (total)	without clamping device	kg	3600	3600	8050	8200
Amplitude	without clamping device/pile	mm	19.6	24.4	26.2	31.0
Displacement	Q Motor (max.)	l/min	425	463/386	719	680
Pressure	p (max.)	bar	350	350	350	350
Power consumption	p (max.)	kW	248	270/228	419	397
Dimensions	Length L	mm	2250	2250	2800	2800
	Width B	mm	777	777	678	678
	Height H	mm	1745	1745	2105	2105
	Throat T	mm	402	402	402	402
Power pack	Type	MS-A	260	260	420	420
Single clamping device	Type	MS-U	100	100	180	200
	alternative Type	MS-U	150	150	–	250
Double clamping device	Type	MS-U	2 x 54	2 x 54	2 x 90	2 x 100
	alternative Type	MS-U		2 x 90/100	2 x 100	

Fixed eccentric moment

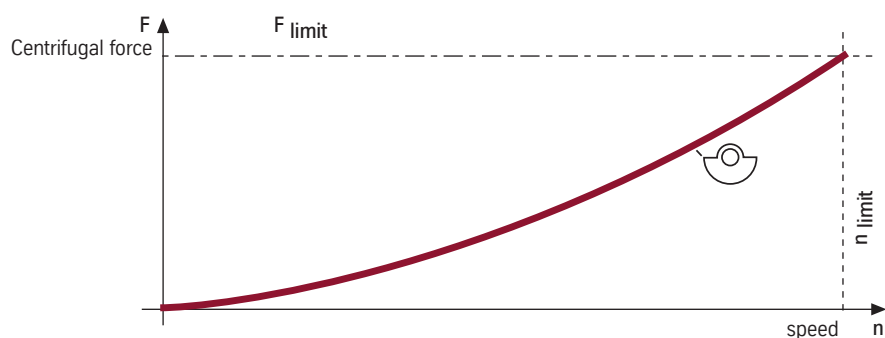

MÜLLER Vibrators HHF-series.

Two in one.

The vibrator can be adapted quickly to different soil conditions by a simple system of adding or removing weights, allowing the eccentric moment to be varied. For example, if high frequency is required for work in loose sand, the additional weights can be removed simply on site to achieve high frequencies with the same centrifugal force.

Applications

- Soils with moderate to heavy driving conditions
- Suitable for heavy piles

Advantages

- Adding or removing weights
- Quick changeover
- Quickly adapted to different soil conditions

Type			MS-25 HHF	MS-50 HHF	MS-100 HHF	MS-120 HHF	MS-200 HHF	MS-240 HHF
Centrifugal force	F (max.)	kN	750	1500	2500	3003	4000	5160
Eccentric moment	M stat (max.)	kgm	25	50	100	116	190	240
Steps (see illustration)		kgm	12/15/20/25	24/30/40/50	48/60/80/100	80/94/110/116	(98)/110/150/190	151/193/218/240
Speed steps	n (max.)	rpm	2170/2113/	2362/2113/	2160/1920/	1850/1700/	(1800)/1800/	1770/1560/
Speed steps	n (max.)	rpm	1830/1637	1830/1637	1670/1500	1570/1536	1560/1371	1470/1400
Frequency steps	f (max.)	Hz	39.3/35.2/	39.3/35.2/	36/32/	30.9/28.3/	30/26/	29.5/26/
Frequency steps	f (max.)	Hz	30.5/27.3	30.5/27.3	27.8/25	26,2/25,6	22.9	24.5/23.4
Pulling force	F pull (max.)	kN	280	500	600	1200	1200	1200
Weight (dynamic)	without clamping device	kg	2900	4500	7700	8900	11750	12010
Weight (total)	without clamping device	kg	3700	6100	10900	15500	18500	19000
Amplitude (steps)	without clamping device/pile	mm	8.3/10.3/	10.7/13.3/	12.5/15.6/	18.0/21.1/	16.7/18.7	25.1/32.1/
Amplitude (steps)	without clamping device/pile	mm	13.8/17.2	17.8/22.2	20.8/26.0	24.7/26.1	25.5/32.4	36.3/40.0
Displacement	Q Motor (max.)	l/min	298/470	610/964	1045/1286	989/1150/1534	1435/1680	1770
Pressure	p (max.)	bar	350	350	350	350	350	350
Power consumption	P (max.)	kW	174/274	356/562	610/750	577/671/895	837/980	1032
Dimensions	Length L	mm	1800	2260	2410	2300	2300	2300
	Width B	mm	813	888	846	1200	1430	1510
	Height H	mm	1885	2465	3235	4135	4170	4190
	Throat T	mm	360	350	500	832	832	832
Power pack	Type	MS-A	260	420/570*	700/840*	840/1050*	840/1050*	1050
Single clamping device	Type	MS-U	90	180	360	360	–	–
	alternative Type	MS-U	100	200	–	–	–	–
Double/quadruple	Type	MS-U	2 x 54	2 x 90	2 x 150	2 x 180	2 x 250	4 x 180
clamping device	alternative Type	MS-U	2 x 70	2 x 100	2 x 180	–	–	4 x 250

* Combination for increased performance

Stepwise variable moment

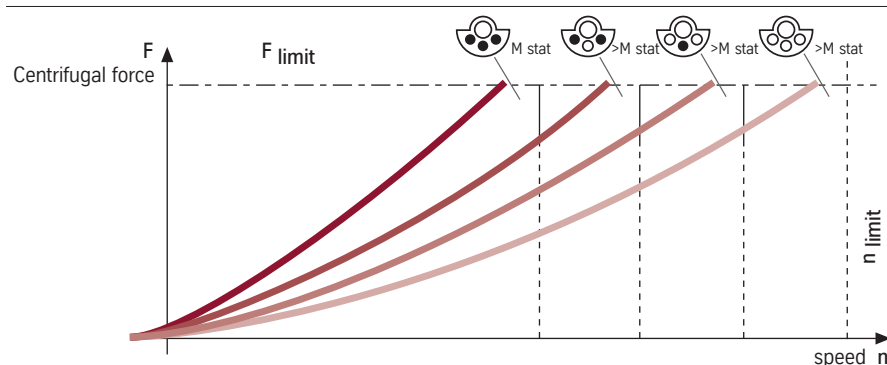

MÜLLER Vibrators HFV-series.

Variable and resonance-free.

The vibrators of this series ensure maximum performance for minimum ground vibration and are therefore ideal for applications in inner-city civil engineering works or in areas sensitive to vibration – guaranteed by the resonance-free starting and stopping. In addition, the amplitude can be infinitely varied during operations. The natural frequency of the soil can therefore be taken into account – driving proceeds effectively and at the same time with little vibration.

Applications

- Inner-city civil engineering works
- Areas sensitive to vibration
- Chiefly sandy soils

Advantages

- Minimal ground vibrations
- Optimum adaptation to soil conditions
- Technology that's easy-going on equipment and environment

Type			MS-10 HFV	MS-16 HFV	MS-20 HFV	MS-24 HFV	MS-28 HFV	MS-32 HFV	MS-40 HFV	MS-48 HFV	MS-62 HFV
Centrifugal force	F (max.)	kN	610	968	1230	1480	1473	1980	2006	2960	2998
Eccentric moment	M stat (variabel)	kgm	0–10	0–16	0–19,5	0–24	0–28	0–32	0–39,2	0–48	0–62
Speed	n (max.)	rpm	2358	2370	2400	2350	2190	2375	2160	2350	2100
Frequency	f (max.)	Hz	39.3	39.5	40.0	39.2	36.5	39.6	36.0	39.0	35.0
Pulling force	F Zug (max.)	kN	180	300	300	400	500	600	600	600	800
Weight (dynamic)	without clamping device	kg	1700	2565	2530	2900	3120	4850	4870	6520	6805
Weight (total)	without clamping device	kg	2300	3530	3600	5050	5320	7250	7280	9700	11165
Amplitude	without clamping device/pile	mm	11.8	12.5	15.4	16.5	18.0	13.2	16.1	14.7	18.2
Power consumption	P (max.)	kW	147/203	297/408	413	404/551	428/514	570/685	630/756	682/823	980/735
Displacement	Q Motor (max.)	l/min	253/348	508/699	708	693/945	734/880	1045/1175	1080/1296	1170/1410	1680/1260
Pressure	p (max.)	bar	350	350	350	350	350	350	350	350	350
Dimensions	Length L	mm	1635	2080	2080	1920	1920	2371	2371	2371	2371
	Width B	mm	732	782	782	893	893	800	880	1123	1180
	Height H	mm	1530	2060	2060	2240	2240	2455	2455	2525	2525
	Throat T	mm	330	350	350	451	451	345	345	860	860
Power pack	Type	MS-A...V	170/260*	260/420*	420	420/570*	420/570*	570/700*	700/840*	700/840*	1050
Single clamping device	Type	MS-U	72	150	150	180	180	250	250	360	360
	alternative Type	MS-U	100								
Double clamping device	Type	MS-U	2 x 54	2 x 70	2 x 90	2 x 90	2 x 90	2 x 150	2 x 150	2 x 180	2 x 180
	alternative Type	MS-U	2 x 70	2 x 90	2 x 100	2 x 100	2 x 100		2 x 180		

* Combination for increased performance

Variable eccentric moment

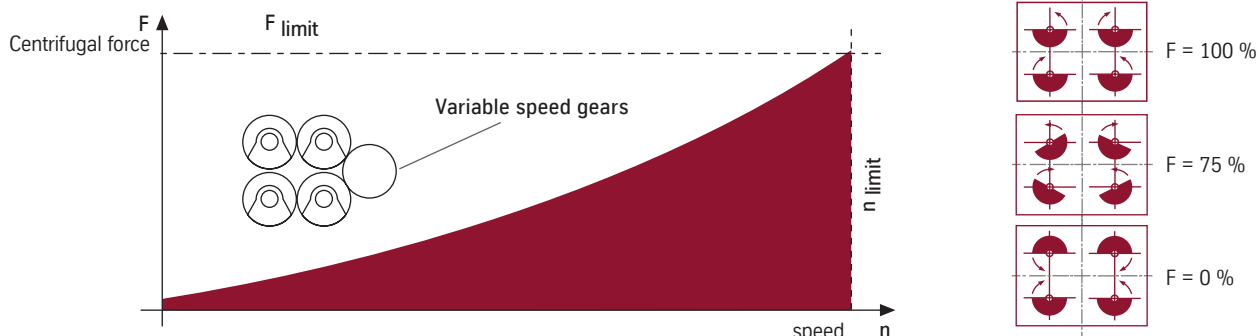

MÜLLER Excavator-mounted vibrators.

Compact all-rounders.

The compact, lightweight MÜLLER excavator-mounted vibrators can be attached to all common excavators. The power comes from the on-board hydraulics and the units are controlled by the excavator's control levers. Various models (HFB, HFBV, HFBS) and useful accessories are available to suit the most diverse applications.



Applications

- General driving, extracting and compacting work (MS-2 to -9 HFB)
- Suitable for sheet piling and tubular piles with a modified clamp arrangement (MS-4 -6,-7 and 9 HFB)
- Installation of plastic and timber piles, lightweight sections, reinforcing cages (MS-1 HFB)
- For vibration-sensitive projects or inner-city areas (MS-5 HFBV, MS-7 HFBV, MS-8 HFBV, MS-10 HFBV)
- Jobs in heavy soils (MS-9 HFB, MS-17 HFB)
- Pile sections can be picked up and set down directly with the clamp (MS-4 to -7 HFBS)

Advantages

- Small and compact
- All vibrators are fitted with a safety circuit
- Quiet and universal in application
- Extremely low height allows driving of long piles
- High push/pull forces increase driving performance
- All clamps can be rotated through 90° to allow face working
- Easy to attach
- Option: double clamping devices can be fitted for driving tubular piles
- Option: cooling system
- Option: monitoring of operating data
- Option: modified for operation with power pack

Technical data at a glance.

MS-HFB / MS-HFBS with fixed eccentric moment.

Type			MS-1 HFB	MS-2 HFB	MS-3 HFB	MS-4 HFB	MS-6 HFB
Centrifugal force	F (max.)	kN	90	245	296	374	464
Eccentric moment	M stat (max.)	kgm	0.7	2.2	3.0	4.2	6.5
Frequency	f (max.)	Hz	56.0	53.1	50.0	47.5	42.5
Speed	n (max.)	rpm	3360	3185	3000	2850	2550
Pulling force	F pull (max.)	kN	34	60	60	120	120
Push down	F push (max.)	kN	34	40	40	80	80
Power consumption	P (max.)	kW	60	61	70	100	119
Total weight (incl. clamping device)		kg	350	815	830	1230	1240
Dyn. weight (incl. clamping device)		kg	230	570	585	940	950
Amplitude		mm	6.1	7.7	10.3	8.9	13.7
Displacement	Q Motor (max.)	l/min	102	105	120	171	204
Length	L	mm	722	1153	1153	1239	1239
Width	B	mm	472	623	623	742	742
Height (incl. clamping device)	H	mm	761	1024	1024	1249	1249
Width at throat	T	mm	230	260	260	340	340
Standard clamping device	Type	MS-U	12	40	40	60	60
Recommended power pack	Type	MS-A				110	110



Type			MS-7 HFB	MS-9 HFB	MS-17 HFB	MS-4 HFBS	MS-6 HFBS	MS-7 HFBS
Centrifugal force	F (max.)	kN	604	606	604	378	464	604
Eccentric moment	M stat (max.)	kgm	7.0	8.5	17.0	4.2	6.5	7.0
Frequency	f (max.)	Hz	46.7	42.5	30.0	47.5	42.5	46.7
Speed	n (max.)	rpm	2800	2550	1800	2850	2550	2800
Pulling force	F pull (max.)	kN	150	150	140	120	120	150
Push down	F push (max.)	kN	80	80	170	80	80	80
Power consumption	P (max.)	kW	130	133	158	100	119	130
Total weight (incl. clamping device)		kg	1300	1380	2208	1360	1370	1380
Dyn. weight (incl. clamping device)		kg	950	990	1453	1110	1120	1130
Amplitude		mm	14.7	17.2	19.8	7.7	11.6	12.4
Displacement	Q Motor (max.)	l/min	224	229	270	171	204	224
Length	L	mm	1239	1239	1714	1410	1410	1410
Width	B	mm	742	762	917	697	697	697
Height (incl. clamping device)	H	mm	1249	1249	1461	1250	1250	1250
Width at throat	T	mm	340	340	340	-	-	-
Standard clamping device	Type	MS-U	72	72	72	60	60	72
Recommended power pack	Type	MS-A	170	170	170	110	110	110

The maximum operating pressure for all excavator-mounted vibrators is 350 bar.

Technical data at a glance.

MS-HFB / MS-HFBS with variable eccentric moment.

Type			MS-5 HFBV*	MS-7 HFBV*	MS-8 HFBV*	MS-10 HFBV
Centrifugal force	F (max.)	kN	400	478	585	588
Eccentric moment	M stat (max.)	kgm	0-5	0-6.7	0-8	0-9.8
Frequency	f (max.)	Hz	45.0	40.0	43.0	39.0
Speed	n (max.)	rpm	2700	2400	2580	2340
Pulling force	F pull (max.)	kN	120	120	150	150
Push down	F push (max.)	kN	80	80	150	150
Power consumption	P (max.)	kW	95/126	112/126	165/120	167/148
Total weight (incl. clamping device)		kg	1580	1600	1815	1865
Dyn. weight (incl. clamping device)		kg	1130	1150	1295	1340
Amplitude (incl. clamping device)		mm	8.8	11.3	12.4	14.6
Displacement five connecting hoses	Q Motor (max.)	l/min	162/216	204/230	283/206	293/257
Displacement three connecting hoses	Q Motor (max.)	mm	180/240	220/250	300/220	-
Length	L	mm	1350	1350	1554	1554
Width	B	mm	707	707	761	761
Height (incl. clamping device)	H	mm	1423	1419	1457	1457
Width at throat	T	mm	390	390	415	415
Standard clamping device	Type	MS-U	60	60	72	72
Recommended power pack	Type	MS-A	110 V	110 V	170 V	170 V

The maximum operating pressure for all excavator-mounted vibrators is 350 bar.

* Option: with three or five connecting hoses

Equipment selection chart

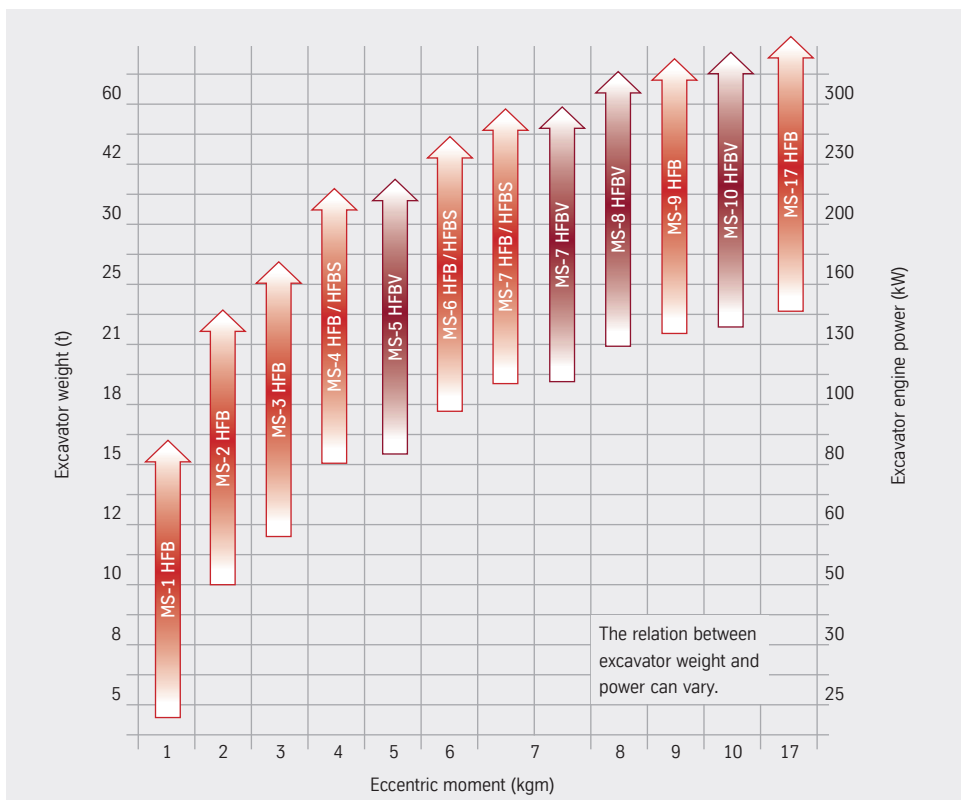

MÜLLER Power packs.

Power and intelligence.

Power packs are needed to drive hydraulic vibrators. Inside a soundproofed housing, a diesel engine drives the hydraulic pump that ensures the necessary flow of oil (required by the hydraulic motor) via hoses to the vibrator.

Every integral diesel engine is a low-noise, low-maintenance unit complying with the latest emissions regulations. Operations can be optimised and monitored via a programmable control connected via cable or a radio link. As an option, operating parameters and machine data can be called up remotely via a data modem.

Advantages

- Small, lightweight design with closed oil circuit
- Good reliability thanks to the use of diesel engines, pumps, controls and other components all well-proved in on-site operations
- Comprehensive range of accessories, e.g. teleservicing package, winter package, or bypass fine filter



Type			MS-A 110 (V)*	MS-A 170 (V)*	MS-A 260 (V)*	MS-A 420 (V)*	MS-A 570 (V)*	MS-A 570 (V)*	MS-A 700 (V)*	MS-A 840 (V)*	MS-A 1050 (V)*	MS-A 1150 (V)*
Diesel motor			CAT	CAT	CAT	CAT	CAT	Volvo-Penta	2 x CAT	2 x CAT	2 x CAT	2 x V-Penta
Type		ATAAC	C 4.4	C 6.6	C 9	C 15	C 18	TAD 1643VE	C 13	C 15	C 18	TAD 1643VE
Exhaust certification		EU/EPA	IIIA/Tier 3	IIIA/Tier 3	IIIA/Tier 3	IIIA/Tier 3	IIA/Tier 2	II/Tier 2	IIIA/Tier 3	IIIA/Tier 3	IIIA/Tier 3	III/Tier 2
Power	P (max.)	kW	106	168	261	433	571	565	708	866	1044	1130
Speed	n (max.)	rpm	2200	2200	2200	2000	1800	1850	2100	2100	2100	1850
Hydraulics												
Feed rate	Q (max.)	l/min	270	310	525	740	1050	1050	1180	1480	1680	2100
Operating pressure	p (max.)	bar	380	380	380	380	380	380	380	380	380	380
Fuel tank capacity		l	400	400	550	900	1050	1050	1400	2200	2200	2200
Hydraulic tank capacity		l	250	250	250	280	440	440	500	600	600	600
Weight without fuel		kg	4000	4000	5000	6200	8500	8500	10300	12500	13500	13800
Dimensions	Length L	mm	3000	3000	3700	4250	4750	4750	4800	5300	5300	5300
	Width B	mm	1400	1400	1490	1700	2000	2000	2200	2400	2400	2400
	Height H	mm	2100	2100	2340	2450	2400	2370	2450	2570	2570	2595

* optionally with variable amplitude

MÜLLER Leader-mounted vibrators.

For tight spaces.



MÜLLER leader-mounted vibrators are the specialists for tight corners. They are mounted on leaders and offer contractors an adjustable moment plus resonance-free starting and stopping.

Applications

- Driving and extracting sheet piles, tubular piles and H-sections
- Foundation methods such as compacted gravel or sand columns
- Driving and extracting single sheet piles with small dimensions

Advantages

- Compact design
- Driving and extracting on cramped sites
- Resonance-free starting and stopping
- Minimum vibrations and emissions

Type			MS-16 HFMV	MS-20 HFMV	MS-30 HFMV
Centrifugal force	F (max.)	kN	986	1160	1535
Eccentric moment	M stat	kgm	0–16	0–20	0–30
Speed	n (max.)	rpm	2370	2300	2160
Frequency	f (max.)	Hz	39.5	38.4	36.0
Pulling force	F pull (max.)	kN	180	180	300
Total weight	incl. clamping device	kg	3980	4110	5690
Dimensions	Height (excl. clamping device) H	mm	1710	1710	2146
	Throat T	mm	455	455	550
Standard clamping device	Type	MS-U	150	150	180

The operating pressure for all leader-mounted vibrators is max. 350 bar.

MÜLLER Drill drives.

Rounding off the range.



These robust, low-noise drilling units are quickly and easily attached to the stick of an excavator. Attachment to a leader or fitting in the clamp of a vibrator are available as options.

Applications

- Pre-drilling to loosen and relieve the ground
- Heavy soils

Advantages

- Various mounting options
- Fast, cost-effective drilling
- Powerful, robust, long life

Type			MS-RHA 12 3*	MS-RHA 16 3*	MS-RHA 24 3*	MS-RHA 34 3*	MS-RHA 46 3*
Torque	(max.)	da Nm	1200	1600	2400	3400	4600
Speed	(max.)	rpm	125	115	110	100	70
Oil pressure	(max.)	bar	350	350	350	350	350
Displacement	(max.)	l/min	260	350	460	600	600
Diameter	smallest drilling diameter	mm	200	200	400	400	400
Diameter	largest drilling diameter	mm	700	900	1200	1400	1600
Weight	without auger/without stand approx.	kg	300	360	440	600	760
Drill depth	with smallest drilling diameter (max.)	m	20	25	14	16	20
Drill depth	with largest drilling diameter (max.)	m	4	4	2	2	2

* Mounted on excavator stick

Options available on request: mounted on leader, fitted in vibrator clamp

MÜLLER Clamping devices.

A safe connection.

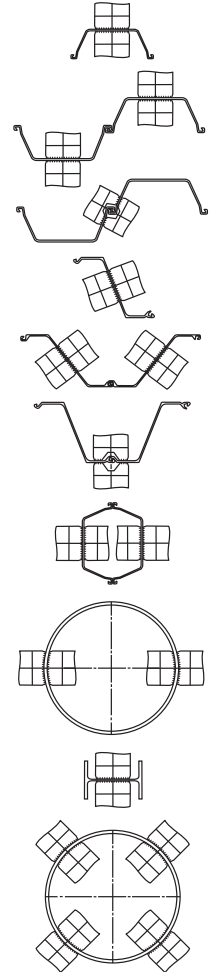
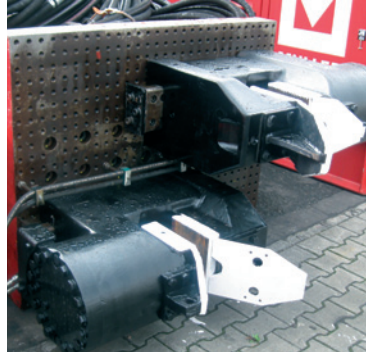

MÜLLER clamping devices

Clamping devices connect the pile section, e.g. H-sections or tubular piles, to the vibrator and transfer the vibrations. All units can be rotated through 90° for face working. Adapter plates are available to cope with different clamping arrangements. Clamps to fit over the interlocks of double piles and radial clamps for driving tubular piles are also available. Important for making the right choice: the clamping force of the clamping device must be at least 1.2 times the centrifugal force of the vibrator.

Applications

- As single and double clamps for U-/Z-sections, H-sections and tubular piles
- As special clamping devices for specific tasks, e.g. timber piles, concrete piles and small-diameter tubular piles

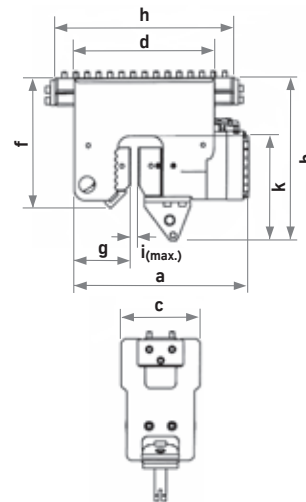

Arrangement of clamps

Clamping devices

Type	Clamping force kN	Clamping pressure bar	Dimensions in mm							i. max.	IPB min	Weight kg
			a	c	d	f	g	h				
MS-U 12*	122	260	229	195	195	223	95	-	15	120	50	
MS-U 40*	370	300	548	260	400	285	175	-	40	120	190	
MS-U 54**	540	350	648	270	515	694	190	730	22	180	440	
MS-U 60*	600	300	640	320	480	350	220	-	40	140	260	
MS-U 70**	700	350	770	340	580	529	290	820	36	180	615	
MS-U 72*	720	358	640	320	480	350	220	-	40	140	260	
MS-U 80/100 A*	1000	350	751	330	510	350	210	-	40	280	400	
MS-U 90**	900	350	770	340	580	529	290	820	28	180	620	
MS-U 100 GP**	1000	350	761	345	610	534	250	780	50	280	750	
MS-U 150 GP**	1500	350	892	340	640	554	309	780	45	320***	920	
MS-U 150 AP*	1500	350	902	360	660	580	319	-	40	320***	940	
MS-U 180 GP**	1800	350	903	390	745	645	325	880	80	320***	1250	
MS-U 180 AP*	1800	350	893	390	740	645	314	-	80	320***	1130	
MS-U 200 A*	2000	350	1011	380	880	800	410	-	48	450	1600	
MS-U 250 G**	2500	350	1173	400	870	840	410	1150	63	450	2450	
MS-U 250 A*	2500	350	1173	395	860	840	380	-	63	450	1950	
MS-U 360 A*	3600	350	1255	460	1180	950	520	-	80	400	3130	

* for direct bolting ** shiftable on clamping bar *** IPB 300 possible with special equipment

MÜLLER Data acquisition.

Mobile measurement, indication and recording of vibrations.

The data acquisition system enables simple and reliable monitoring of the driving process to ensure that the design requirements are adhered to. The system records operating parameters such as operating frequency and vibrator oil pressure. In addition, ground vibrations can be measured via a three-axis geophone according to DIN 4150. When using water-jetting equipment to assist driving, the water pressure and flow rate can also be recorded.

MS-DATA

The data acquisition equipment is integrated directly into the drive's control unit. The data can then be sent via cable to a computer on site or via modem and data transmission to an Internet server for safe storage. The data can be called up from any computer with Internet access after entering the necessary password. Bespoke record forms to suit customers' requirements are also possible. The power pack control automatically regulates the operating parameters of the vibrator so that given vibration limits for ground or buildings are not exceeded.

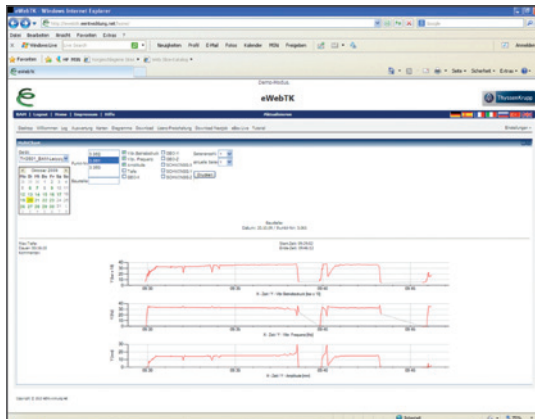

MS-DATA M

MS-DATA M is the mobile version of the measuring system for flexible usage without a power pack. The data is transferred to a measuring unit and shown on a display. Vibration limits are easy to set on the device; if these are reached, yellow and red lamps warn the user. The system can also be fitted with a modem for saving the data to an Internet server for further processing.

Advantages

- Optimum system compatibility – everything from one supplier
- Vibration monitoring to DIN 4150
- Constant monitoring of operating parameters
- Recording of multiple parameters
- Safe data storage to protect against loss
- Simple records

MÜLLER Accessories.

The right extras for every application.

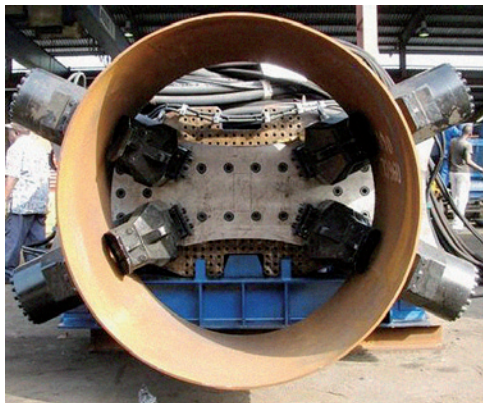

Bracket

So-called X-brackets are available in various sizes for driving large-diameter, heavy, tubular piles.

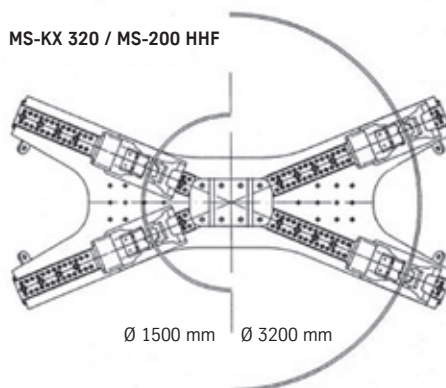

MÜLLER safety shackle

The MÜLLER safety shackle, available in various sizes, is ideal for picking up piles quickly and safely. At the same time, it guarantees easy, safe pitching of piles.

Advantages

- Easy to use
- Low weight
- Twin fastening prevents opening under load

Type	Tensile load kN	Weight kg
MS-SSZ-3 B	30	15
MS-SSZ-4 B	40	24
MS-SSZ-5 B	50	26



MÜLLER universal connecting fork for excavator-mounted units

This accessory enables MÜLLER excavator-mounted vibrators and drilling units to be attached to the majority of excavators. It is fitted with three different connecting pins. The benefits are the fast changeover from drilling unit to vibrator and the stable construction.

Other connecting forks on request.

MÜLLER Accessories.

The right extras for every application.



MÜLLER winter package for power packs

For use in temperatures down to -25°C .

The winter package contains:

- Preheaters for hydraulic oil and diesel engine cooling water, with external power supply (220–240 V)
- Option: set of covers for closing off the unit's air intakes and air outlets
- A reduced air flow through the unit to help the unit reach its operating temperature faster
- Operation with some air intakes and air outlets closed depending on the ambient temperature
- Better economy thanks to faster deployment and fuel-savings
- Furthermore, the components benefit from preheating, which improves their operational readiness and prolongs their service life.



MÜLLER fine filters

The bypass oil filter is a filter system that supplements the hydraulic filter already fitted. The bypass oil filter is used for the fine filtering of the hydraulic oil. The lower flow rate via the filter means that a much finer filter can be selected than is the case with standard filter elements. Therefore, much finer particles can be removed from the oil than is the case with full-flow oil filters. Bypass filters are available for all MÜLLER power packs.

Advantages

- Prolongs the life of the hydraulic oil and the system components
- Avoids acids in the oil through absorption of water
- Fewer malfunctions thanks to the improved cleanliness of the hydraulic oil
- Reduced repair costs and downtimes
- Reduced load on primary filters and therefore lower maintenance costs

Other accessories

Timber pile clamping device

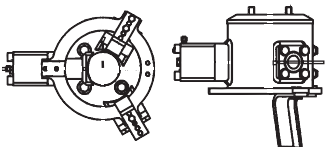

Stick extension
("goose neck")

to increase usable piling length

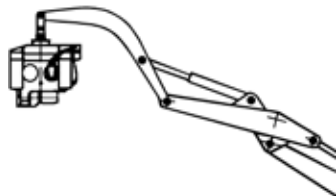

Adapter plate /
double clamping devices

for driving tubular piles

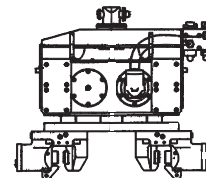

MÜLLER Special equipment.

Special expertise.



Expert consulting services often make a decisive contribution to success when special challenges have to be met. Our engineers specialised in machine design, control technology and electronics, geotechnical and foundation engineering are available to help you.

MÜLLER 5-fold clamping device

The adapter plate enables five clamping elements to be attached to five straight-web sections. These are arranged on a radius so that the sections can be clamped and installed simultaneously. This is an efficient way to counter buckling of the section.



DYSTAFIT®

Dystafit® can be used to optimise soil improvement and rehabilitation measures. It does this by simulating loading cycles, which enables valid statements to be made about the stability of a soil that is sensitive to settlement, subsidence or shifting. In addition, this method is useful for assessing the effects of higher speeds on railway lines.



MÜLLER acoustic hood

The newly developed acoustic hood reduces noise emissions but does not hamper servicing nor the escape of unwanted heat.

Advantages

- Lower noise levels
- Special access openings permit maintenance and servicing without removing the hood
- Additional vertical weight on spring suspension unit
- Easy to store and transport

MÜLLER Special equipment.

Special expertise.



MÜLLER MS-BDE

Autonomous operating data acquisition for excavator-mounted vibrators

- Acquisition, storage and read-out of operating data: date, operating hours, max. operating temperature
- Helps to comply with service intervals
- Easy for customers to use
- Compatible with all makes

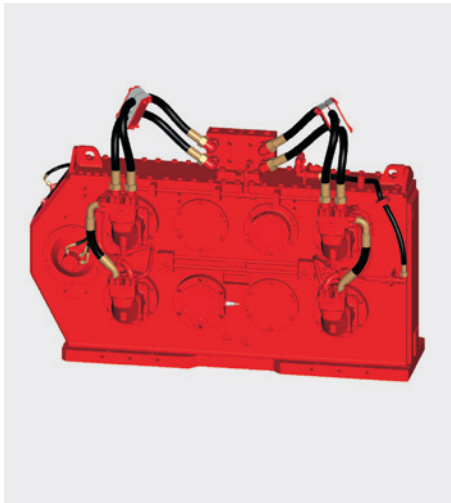

MÜLLER MS-32 HFV vibrator

When fitted with a special compacting plate, the MÜLLER MS-32 HFV vibrator can be used for soil compaction. It can even be used underwater.

- Variable from 0 to 40 Hz
- Special sensors measure r.p.m. and detect angles during the compaction process
- Modified for continuous operation and underwater use
- Approved for 10° gradient in all directions
- Automatic compaction cycle (start/compact/stop)
- Optional: radio remote control with automatic display of operating data, amplitude and static moment
- Optional: graphic display via MS-DATA and webTK
- Powered by MÜLLER power pack



MÜLLER MS-U 160 S clamping device

- Internal clamping for foundations with thin-wall tubes and very small diameters (d = approx. 120 mm, depending on wall thickness and length)
- Does not damage the coating on tubes
- Also suitable for use in heavy soils
- Reduces the number of operations normally required



Exclusive sales by:

Head Office

GERMANY

Export

Hollestr. 7a, 45127 Essen, Germany
Phone +49 201 844-563975
Fax +49 201 844-563974
export-bautechnik@thyssenkrupp.com

Export Eastern Europe

Hollestr. 7a, 45127 Essen, Germany
Phone +49 201 844-563895
Fax +49 201 844-563772
osteuroopa-bautechnik@thyssenkrupp.com

ThyssenKrupp Tiefbautechnik GmbH

Alte Liederbacher Straße 6
36304 Alsfeld, Germany
Phone +49 6631 781-131/132
Fax +49 6631 781-130
Service Hotline +49 6631 781-122
Spare Part Service +49 6631 781-126
24 Hours Hotline +49 170 6326650
tiefbautechnik@thyssenkrupp.com
www.thyssenkrupp-tiefbautechnik.com

Sales Branches

AUSTRALIA, JAPAN, NEW ZEALAND

ThyssenKrupp Steelcom Pty. Ltd.
Suite 3, 17-23 Myrtle Street
NSW 2060 North Sydney, Australia
Phone +61 2 94091-777
Fax +61 2 99554-298
www.tk-steelcom.com.au

BRAZIL

ThyssenKrupp Bautechnik do Brazil
Av. das Américas 3500
bloco 06, salas 407/408
CEP 22631-003 Barra da Tijuca
Rio de Janeiro, Brazil
Phone +55 21 32825-245
www.estacas-prancha.com

CHINA, HONG KONG, SEA, TAIWAN

ThyssenKrupp Bautechnik Hong Kong
7F, Sun Hung Kai Centre
30 Harbour Road, Wanchai
Hong Kong SAR, China
Phone +852 318 179-01
Fax +852 318 179-30
www.sheetpiles-asia.com

KAZAKHSTAN

ThyssenKrupp Bautechnik Kazakhstan
050051 Almaty
Prospect Dostyk, 240, office 503,
Kazakhstan
Phone +7 701 736-9684
Fax +7 727 258-5712
www.tkbt.ru

ROMANIA

ThyssenKrupp Bautechnik Romania
50 Av. Petre Cretu Street
012052 Bucharest, Romania
Phone +4 021 319-2417
Fax +4 021 319-2425
office@thyssenkrupp.ro

RUSSIAN FEDERATION

000 ThyssenKrupp Bautechnik Technischer Service
Beloostrowskaya 20/B, of. 65 B
197342 St. Petersburg
Russian Federation
Phone +7 812 337-6510
Fax +7 812 337-6511
www.tkbt.ru

ThyssenKrupp Bautechnik Russia

Ul. Vinogradnja 238 A, Office 11
354000 Sochi, Russian Federation
Phone +7 862 290-1852
Fax +7 862 290-1853
www.tkbt.ru

UKRAINE

ThyssenKrupp Bautechnik Ukraine

Ul. Suvorova 4/6
Office 1104
01010 Kiev, Ukraine
Phone +38 044 280-9905
Fax +38 044 280-1507
info@thyssenkrupp.in.ua
www.tkbt.ru

UNITED ARAB EMIRATES, IRAQ

ThyssenKrupp Bautechnik Dubai

Jebel Ali Office
P.O. Box 262994, Dubai
Dubai, United Arab Emirates
Phone +971 4 887-1618
Fax +971 4 7059-301
www.sheetpiling.ae

ThyssenKrupp Bautechnik GmbH

P.O. Box 10 22 53 · 45022 Essen, Germany
Hollestr. 7a · 45127 Essen, Germany
Phone +49 201 844-562313 · Fax +49 201 844-562333
www.thyssenkrupp-bautechnik.com · bautechnik@thyssenkrupp.com

