

A200 HD CFA

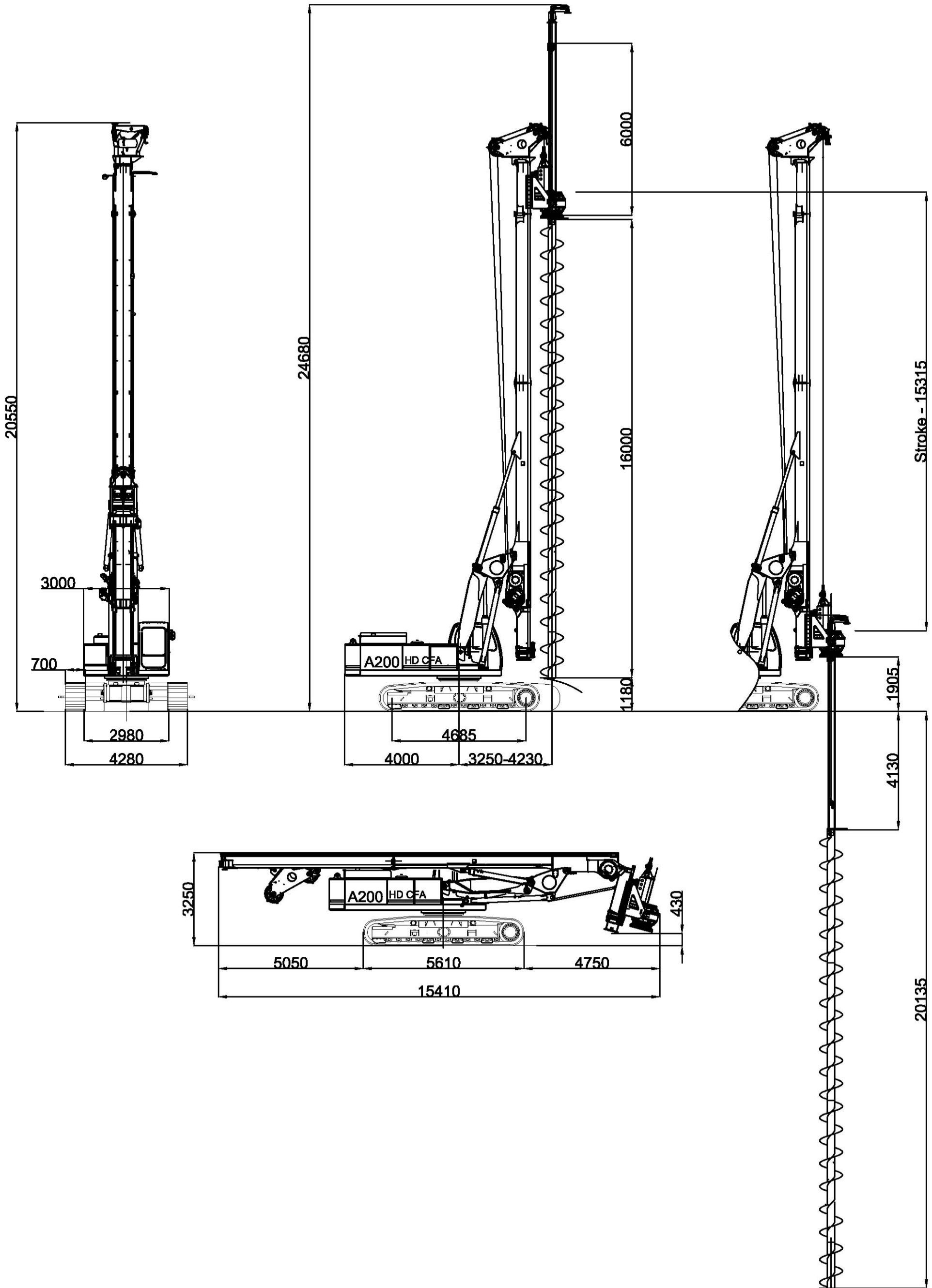



A200 HD CFA

Base		IMT
Undercarriage length / widening range / shoe	mm	5605/2980 - 4280/700
	in	221/117 - 169/27,5
Engine type		CAT C 9
Power		261 KW (350 HP) @1800 rpm
Rotary		
Nominal torque	kNm	205
Working speed		10-26
Winches		
Main winch pull force	kN	200
Main winch speed	m/min	37
Main winch Cable diameter	mm	26
Auxiliary winch pull force	kN	80
Auxiliary winch Speed	m/min	85
Auxiliary winch Cable diameter	mm	18
Pull in 2nd system		
Extraction force	kN	400
Rotary stroke	mm	15315
Drilling depth w/o auger extension		14,135
Drilling depth maximum with auger extension	m	20,135
Mast		
Mast raking forward		5°
Mast side raking		+ 8°
Mast raking backwards		15°
Pile max. diameter	mm	1000
Operating Weight w/o auger	t	53,5